

BALCONGLAS FALCE-ISO

€ ▶ C.320

SISTEMA CON CANALINA / SYSTEMS WITH BOTTOM GUIDE / SYSTEM MIT BODENFÜHRUNG

- Sistema a pannelli mobili in vetro, impacchettabili senza la baia di parcheggio, con canalina a terra, con profili per anta intelaiata, misure standard per anta max 1000 x 3000 mm da tagliare cliente.
- Slide and turn system, with floor channel and without parking bay, with profiles for framed glass door, standard measures up to 1000 x 3000 mm, cut by installer.
- Schiebe-Dreh-Systeme mit beweglichen Glasmodulen ohne Parkraum, mit Bodenschiene. Flügelrahmen für standard Tür max 1000 x 3000 mm. Schnitt bauseitig



- Indicare sempre il verso di apertura e lo spessore vetro
- Please specify always opening direction and glass thickness
- Bitte immer Öffnungsrichtung und Glasdicke angeben

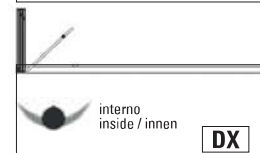
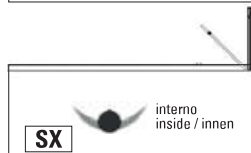
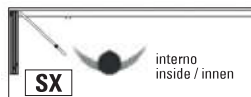

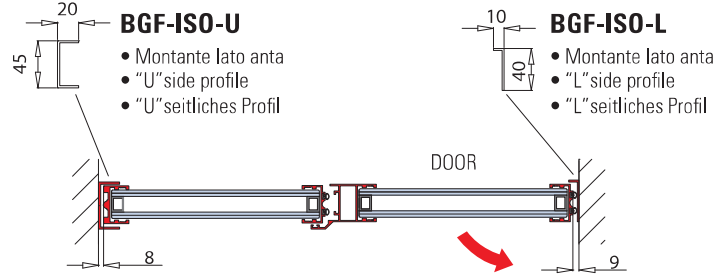
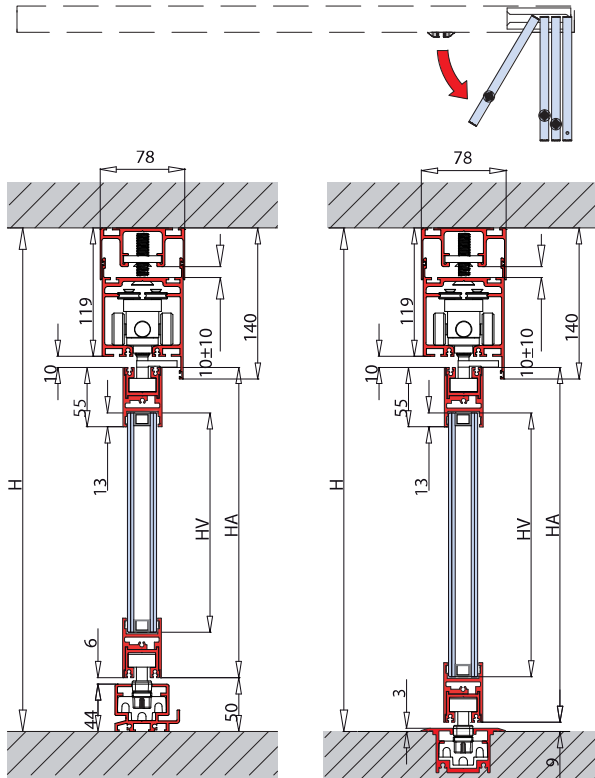
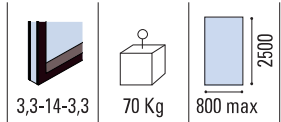
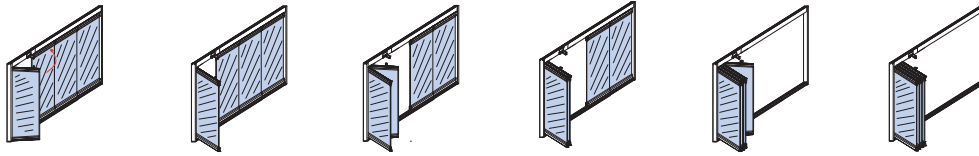

- ! Con i montanti calcolare 6 mm in più di aria.**
! With side profiles to calculate 6 mm extra clearances.
! Mit seitlicher Profile 6 mm extra Spalt zu berechnen.

- Canalina incassata BGM-110
- Recessed floor profile BGM-110
- Versenkte Bodenschiene BGM-110

BG-ISO-SET 2 (LB MAX = 2000 mm)	A B
BG-ISO-SET 3 (LB MAX = 3000 mm)	A B C
BG-ISO-SET 4 (LB MAX = 4000 mm)	A B C C
BG-ISO-SET 5 (LB MAX = 5000 mm)	A B C C C
BG-ISO-SET 6 (LB MAX = 6000 mm)	A B C C C C

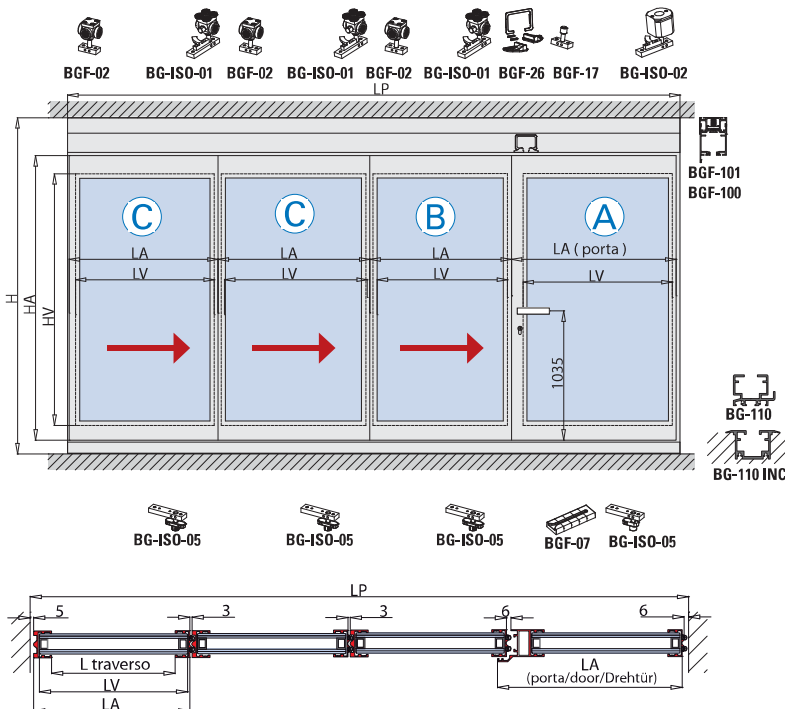

- Lavorazione montante porta per serratura.
- Vertical door Profile preparation for lock.
- Drehtür Profilbearbeitung für Schloss.
- Lavorazione montante anta per contro-serratura.
- Vertical sliding panel preparation for lock's strike plate.
- Schiebeflügel Profilbearbeitung für Schliesblech.

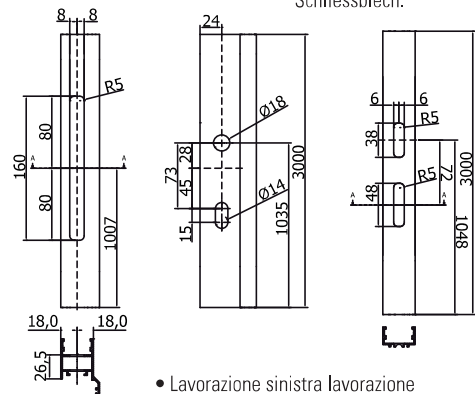

- Lavorazione sinistra lavorazione speculare per la porta destra.
- Left. For right reflecting preparation.
- Links. Für Rechts Spiegelbildlich Bearbeitung.

LP
Passaggio luce
Clear opening width
Lichte Durchgangsbreite

LA = LV
Larghezza ante = Larghezza vetro
Panel width = Glass width
Flügelbreite = Glasbreite

H
Altezza passaggio luce
Clear opening height
Lichte durchgangshöhe

HV
Altezza vetro
Glass height
Glashöhe

HA
Altezza anta
Door height
Tür Höhe

xme426

BALCONGLAS FALCE-ISO

COME USARE **MY METALGLAS** / HOW TO USE **MY METALGLAS** / WIE MAN BENUTZT **MY METALGLAS**

1

INSERIRE LE MISURE DEL TUO VANO E LE ANTE DESIDERATE
ENTER THE MEASUREMENTS OF YOUR OPENING AND THE DOORS YOU REQUIRE
GEBEN SIE DIE MASSE IHRER ÖFFNUNG EIN UND DIE ERFORDERLICHEN TÜREN

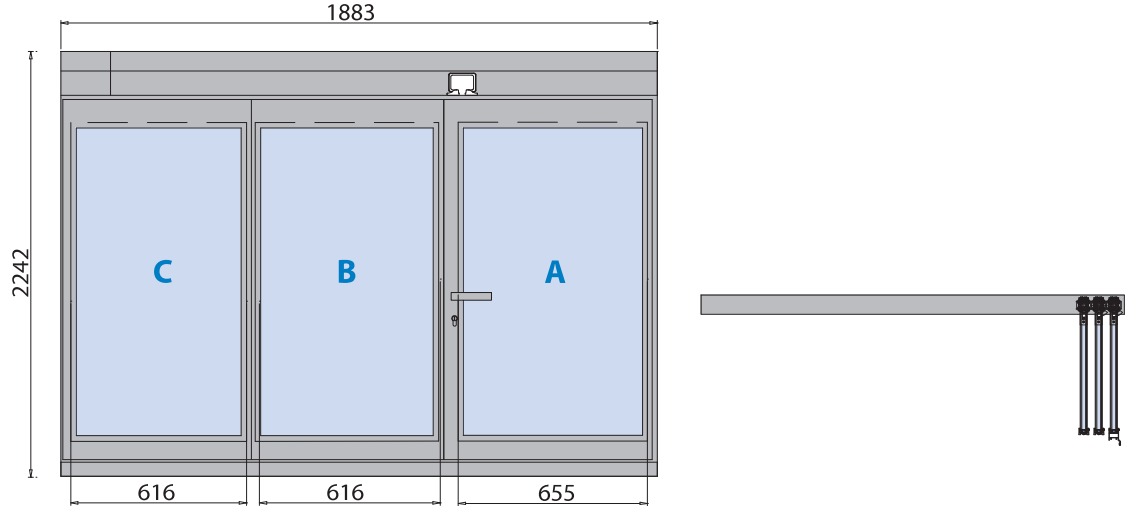

2

SI OTTENGONO LE MISURE DEI VETRI AUTOMATICAMENTE
THE MEASUREMENTS OF THE GLASS WILL BE GENERATED AUTOMATICALLY
DIE ABMESSUNGEN DES GLASES WERDEN AUTOMATISCH BERECHNET

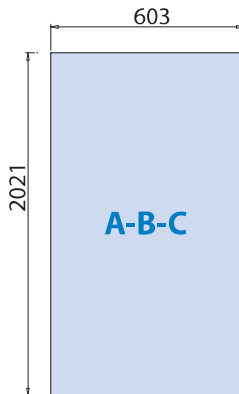

3

SI OTTENGONO LE DISTINTE DI TAGLIO DEI PROFILI, DA ABBINARE AGLI ACCESSORI
THE CUTTING SPECIFICATIONS OF THE PROFILES ARE OBTAINED, FOR MATCHING WITH THE ACCESSORIES
SIE ERHALTEN EINE SPEZIFIKATION DER PROFILLÄNGEN ZUM ABGLEICHEN MIT DEM ZUBEHÖR

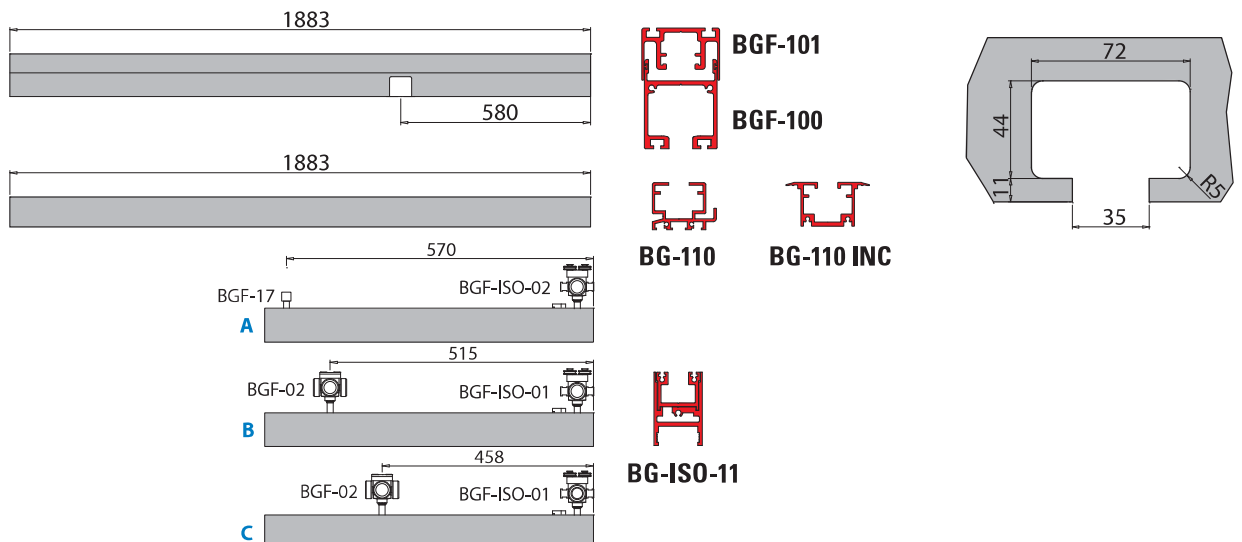

BALCONGLAS FALCE-ISO

COME ASSEMBLARE LE ANTE / HOW TO ASSEMBLE THE DOORS / WIE DIE TÜREN ZUSAMMENSETZT WERDEN

TAGLIO PROFILI
PROFIL PREPARATION / PROFILBEARBEITUNG

+

KIT ACCESSORI
ACCESSORY SETS / ZUBEHÖR SETS

=

ANTA COMPLETA
COMPLETE DOOR / KOMPLETTE TÜR

ANTA A / DOOR A / TÜRA

BG-ISO-ANT-A-DX / BG-ISO-ANT-A-SX
PORTA LATERALE A
LATERAL PIVOT DOOR A
DREHFLÜGEL A

ANTA B / DOOR B / TÜR B

BG-ISO-ANT-B-DX / BG-ISO-ANT-B-SX
ANTA INTERMEDIA B
INTERMEDIATE PANEL B
MITTIGE FLÜGEL B

ANTA C / DOOR C / TÜR C

BG-ISO-ANT-C-DX / BG-ISO-ANT-C-SX
ULTIMA ANTA C
LAST PANEL C
ENDFLÜGEL C