

# PA-450 LIBRO FOLDING do-it-yourself

€ C.160

SCORREVOLI A LIBRO / SLIDING FOLDING SYSTEMS / FALT-SCHIEBEWANDSYSTEME



- Sistema scorrevole modulare a libro con morsetti fermavetro (mm 250) e veletta continua (mm 1200) da tagliare secondo necessità a cura del cliente.
- Sliding folding door system with glass fixing clamps (mm 250) and continuous covers (mm 1200) to be cut on the basis of client's requirements.
- Modulares Schiebesystem mit Glashalteklammern (250 mm) und kontinuierlicher Verkleidung (1200 mm), kundenspezifisch ablängbar.

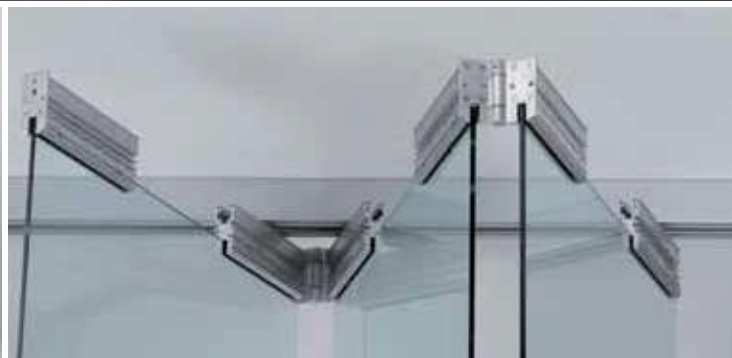
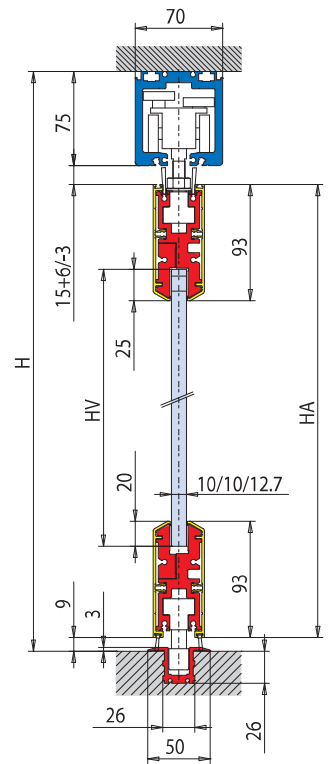

LAVORAZIONE VETRO x 2  
GLASS PREPARATION x 2  
GLASBEARBEITUNG x 2

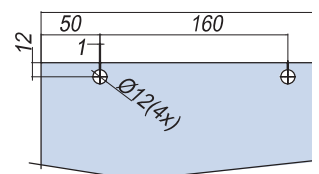

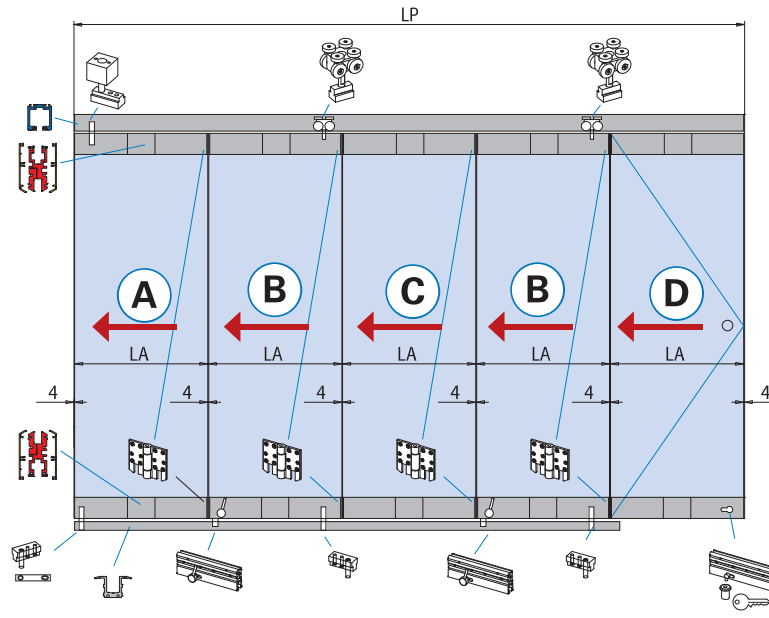
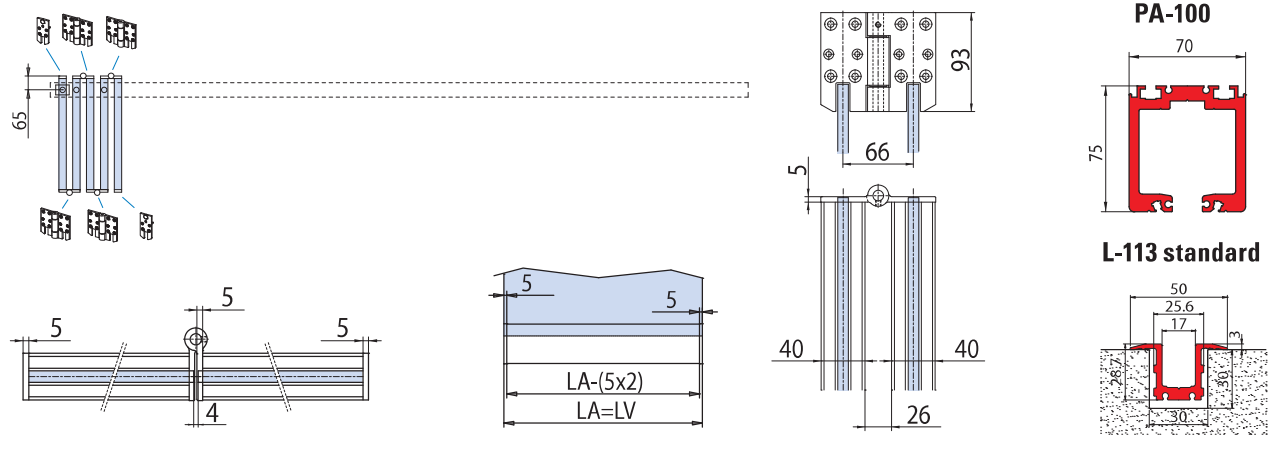
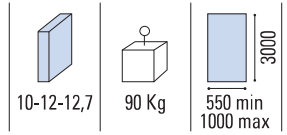
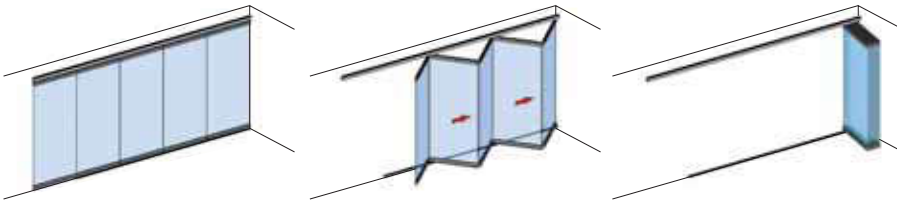

**Calcolo vetro**  
**Calculation glass**  
**Glasberechnung**

$A_t = 4 \times (N + 1)$   
 $X = LP - A_t$   
 $X = N \times LA$   
 $LA = LV = X / N$

- (A)**
- Prima anta a libro
  - First folding panel
  - Erster Faltelement

- (B) (C)**
- Anta intermedia a libro
  - Middle folding panel
  - Mittiges Faltelement

- (D)**
- Ultima anta porta battente con numero ante dispari
  - Last hinged door with odd no. panels
  - Letzter Dreh-Flügel bei ungerader Flügelanzahl

- (E)**
- Ultima anta con N° ante pari
  - Last panel with even no. panels
  - Letzter Flügel bei gerader Flügelanzahl

	PA-450 SET 2 (A) (E)
	PA-450 SET 3 (A) (B) (D)
	PA-450 SET 4 (A) (B) (C) (E)
	PA-450 SET 5 (A) (B) (C) (B) (D)
	PA-450 SET 6 (A) (B) (C) (B) (C) (E)
	PA-450 SET 7 (A) (B) (C) (B) (C) (B) (D)

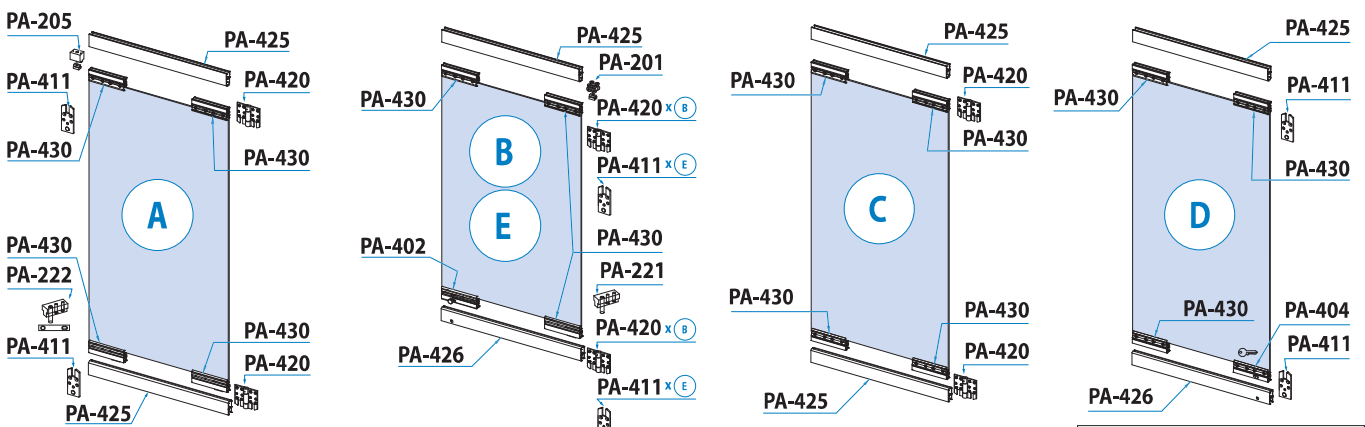

- (B)**
- Anta intermedia con catenacciolo
  - Middle panel with latch
  - Zwischenflügel mit Riegel
- (E)**
- Ultima anta con N° ante pari
  - Last panel with even no. panels
  - Letzter Flügel bei gerader Flügelanzahl

- (D)**
- Ultima anta a porta battente con n° ante dispari
  - Last hinged door with odd no. panels
  - Letzter Drehflügel bei ungerader Flügelanzahl

xla334-0 / xla334g / xla334c

AN	At	N	LP	LA = LV	H	HV	HA
Alluminio anodizzato	Arie totali	Numero ante	Passaggio luce	Larghezza ante = Larghezza vetro	Altezza passaggio luce	Altezza vetro	Altezza anta
Aluminium anodized	Total clearances	Numbers panels	Clear opening width	Panel width = Glass width	Clear opening height	Glass height	Door height
Aluminium Silberfarbig	Summe alle Abstände Glas/Wand	Anzahl der Elemente	Lichte Durchgangsbreite	Flügelbreite = Glasbreite	Lichte durchgangshöhe	Glashöhe	Tür Höhe

SCORREVOLIA LIBRO SLIDING FOLDING SYSTEMS