

Vanity

2025

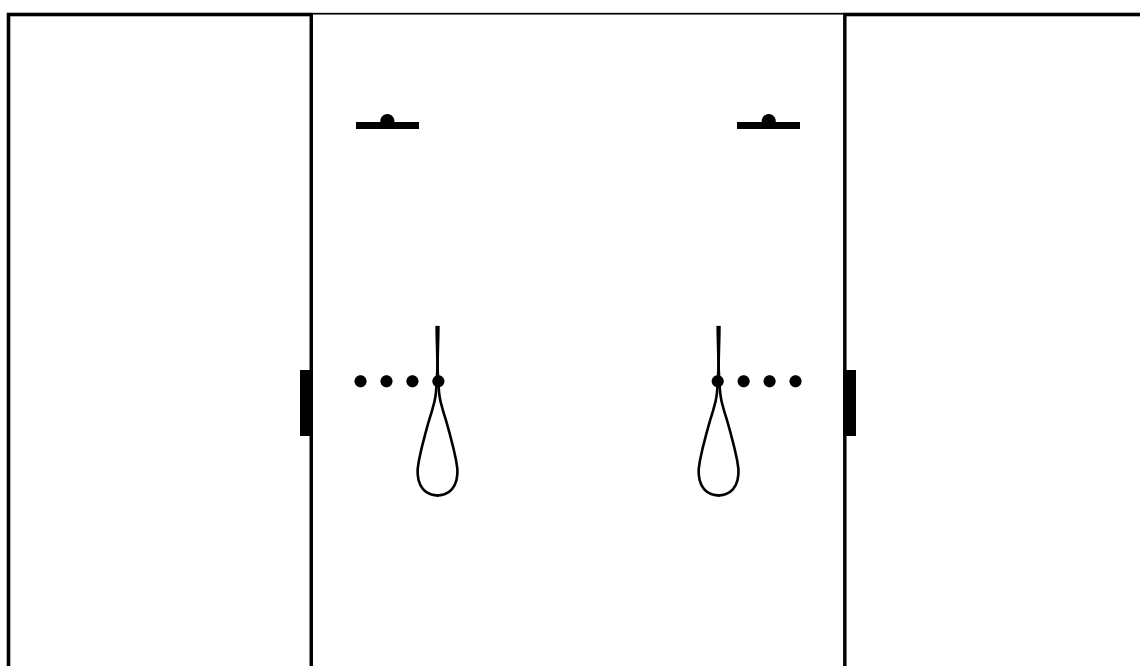

Vanity

Il sistema polifunzionale multistanza

The multifunctional multi-room system
Das multifunktionale Multiroom-System
Le système multifonctionnel multiroom

Il metallo ci appartiene

Metal belong to us

Das Metall gehört uns

Lés metal nous appartient

Siamo un'azienda leader a livello mondiale nella lavorazione dei metalli che offre ai propri clienti un'ampia gamma di prodotti semilavorati per la realizzazione di sistemi per vetro: accessori per elementi scorrevoli, cerniere e serrature, maniglie e maniglioni, pensiline e balaustre, box doccia. I prodotti Metalglas Bonomi si caratterizzano per funzionalità e design, conferendo valore ed eleganza non solo alla casa, ma anche all'ufficio o all'ambiente pubblico di prestigio. Fondata nel 1925 dalla famiglia Bonomi, l'azienda si inserisce nel solco della tradizione imprenditoriale e produttiva del distretto di Lumezzane, in provincia di Brescia, conosciuto in tutto il mondo per la lavorazione del metallo. Nel corso degli anni il continuo perfezionamento tecnologico, la costante attenzione al design e la ricerca di nuove soluzioni, hanno permesso all'azienda di specializzarsi sempre più nella produzione di sistemi per vetro.

We are a world-leading company in metalworking, which offers its customers a wide range of semi-finished products for the creation of glass structures: accessories for sliding systems, hinges and locks, handles and pullhandles, railing and canopy systems, shower enclosures. Metalglas Bonomi products are characterized by functionality and design, enhancing value and elegance not only to the home but also to the office or prestigious public environments.

The Bonomi family started in business in 1925 and can trace its roots in the centuries old business and production areas of Lumezzane, Italy. This area is recognised worldwide for its rich tradition in the manufacture of superior quality metalwork. Thanks to the continuous efforts and investment over time in technological improvement, in the perfection of the details and design and in developing new solutions, the company has been able to specialize more and more in the production of systems for glass.

Wir sind ein weltweit führendes Unternehmen in der Metallverarbeitung, das seinen Kunden eine breite Palette von Halbfertigprodukten für die Herstellung von Glassystemen bietet: Zubehör für Schiebetürsysteme, Scharniere und Schlösser, Griffe und Stoßgriffe, Geländer- und Vordachsysteme, Duschkabinen. Die Produkte von Metalglas Bonomi zeichnen sich durch ihre Funktionalität und ihr Design aus. Sie verleihen nicht nur der Wohnung, sondern auch dem Büro oder einem repräsentativen öffentlichen Raum Wert und Eleganz. Das Unternehmen wurde von der Familie Bonomi im Jahre 1925 gegründet. Das Unternehmen hat seine Wurzeln in der jahrhundertealten Geschäfts- und Produktionstradition des Gebiets von Lumezzane, das weltweit als Zentrum für die Bearbeitung von Metallen in höchster Qualität bekannt ist. Dank der kontinuierlichen Bemühungen um die technologische Verbesserung, in der Perfektion der Details und des Designs sowie in der Entwicklung neuer Lösungen, konnte sich das Unternehmen im Laufe der Zeit immer mehr auf die Herstellung von Systemen für Glas spezialisieren.

Nous sommes une entreprise leader au niveau mondial dans le domaine de la métallurgie, qui offre à ses clients une vaste gamme de produits semi-finis pour la création de systèmes en verre : accessoires pour systèmes coulissants, charnières et serrures, poignées et poignées de tirage, systèmes de garde-corps et d'auvents, cabines de douche.

Les produits Metalglas Bonomi sont caractérisés par leur fonctionnalité et leur design, ce qui leur permet d'ajouter de la valeur et de l'élégance non seulement à la maison, mais aussi au bureau ou à un environnement public prestigieux.

La famille Bonomi commence son aventure commerciale en 1925.

L'entreprise plonge ses racines dans la tradition commerciale et productive séculaire de la région de Lumezzane, connue dans le monde entier comme un centre de qualité supérieure pour l'usinage des métaux.

Grâce aux efforts continus déployés au fil du temps pour améliorer la technologie, perfectionner les détails et le design et développer de nouvelles solutions, l'entreprise a pu se spécialiser de plus en plus dans la production de systèmes pour le verre.

Per anni il bagno è stato considerato come un ambiente da nascondere. La parola "servizi" descrive bene il pensiero comune rispetto a questa parte della casa. Ora, sempre più spesso, è l'ambiente che più rappresenta l'identità di chi lo progetta o possiede, un luogo dove ogni elemento è frutto della più alta ricerca sulla materia e sul design. Sulla scia di questa nuova visione abbiamo creato la collezione di docce con apertura ad anta battente intelaiata VANITY. Estetica, tecnologia e qualità sono tratti distintivi di questo prodotto e rappresentano a pieno la filosofia di Metalglas Bonomi.

In der Vergangenheit galt das Badezimmer als ein Raum, der im Verborgenen gehalten werden sollte, ein Servicebereich, der im Vergleich zum Rest des Hauses keinen Wert hatte. Heutzutage wird jedoch das Badezimmer als ein Raum betrachtet, der die Identität und den Stil des Hauses und seiner Besitzer repräsentiert und charakterisiert, ein Ort, an dem jedes Element das Ergebnis höchster Forschung in Bezug auf Materialien und Design ist. In Anlehnung an diese neue Vision hat Metalglas VANITY entwickelt, die neue Kollektion von umrahmten, schwenkbaren Duschen. Ästhetik, Technologie und Qualität sind die charakteristischen Merkmale dieses Produkts und repräsentieren die Philosophie von Metalglas Bonomi.

In the past the bathroom was considered an environment to be kept hidden, a service area not valued compared to the rest of the house. Nowadays, however, it is considered an environment that represents and characterizes the identity and style of the house and its owners, a place where every element is the result of the highest research into materials and design. Following this new vision, Metalglas developed VANITY, the new collection of framed hinged showers. Aesthetics, technology and quality are distinctive features of this product and fully represent the philosophy of Metalglas Bonomi.

Dans le passé, la salle de bain était considérée comme un espace caché, une zone de commodités peu valorisée par rapport au reste de la maison. Aujourd'hui, elle est considérée comme un environnement qui représente et caractérise l'identité et le style de la maison et de ses propriétaires, un endroit où chaque élément est le résultat d'une recherche poussée en matière de matériaux et de design. C'est en suivant cette nouvelle vision que Metalglas a développé VANITY, la nouvelle collection de douche a porte battante encadrée. L'esthétique, la technologie et la qualité sont les caractéristiques distinctives de ce produit et représentent pleinement la philosophie de Metalglas Bonomi.

Vanity





8

Vanity

All-in-one: Vanity ridefinisce il concetto di flessibilità progettuale.

All-in-one: VANITY
redefines the concept
of design flexibility.

Alles in einem: VANITY
definiert das Konzept der
Design-Flexibilität.

Tout en un : VANITY
redéfinit le concept de
flexibilité de conception.



VANITY-SET4

OS
Finitura / Finish /
Oberfläche / Finition

POR-0400V
Maniglia / Handle / Griff /
Poignée

VANITY-SET2

BV
Finitura / Finish / Oberfläche
/Finition

POR-0400V
Maniglia / Handle / Griff / Poignée



DIV-7800 LUCE

BV
Finitura / Finish / Oberfläche
/Finition

DIV-008
Maniglia / Handle / Griff / Poignée



Metalglas



VANITY-SET9

NO
Finitura / Finish / Oberfläche
/Finition

POR-0400V
Maniglia / Handle / Griff / Poignée

12

Vanity



VANITY-SET6

NO
Finitura / Finish / Oberfläche
/Finition

POR-0400V
Maniglia / Handle / Griff / Poignée

Vanity può essere integrata con la nostra nuova collezione di porte scorrevoli ottenendo una continuità di forme e finiture.

Vanity can be integrated with our new collection of sliding doors, to offer continuity of design and finishes.

Vanity kann in unsere neue Schiebetürenkollektion integriert werden, um die Kontinuität der Formen und Oberflächen zu gewährleisten.

Vanity peut être intégré à notre nouvelle collection de portes coulissantes, pour offrir une continuité de formes et de finitions

VANITY-SET5

NO
Finitura / Finish / Oberfläche /
Finition

POR-0400V
Maniglia / Handle / Griff / Poignée





Caratteristiche tecniche

Features

Eigenschaften

Caractéristiques techniques

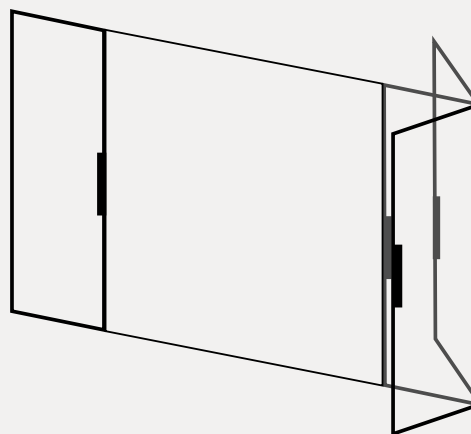

Apertura sia interna che esterna

Inward and outward opening
Beidseitig öffnend
Ouverture vers l'intérieur et l'extérieur

Profili perimetrali minimali

Minimal perimeter profiles

Minimale Rahmenprofile

Profils de périmètre minimaux



Cerniera inferiore con movimento saliscendi

Bottom hinge with lift-lower function

Unteres Band mit Hebe-Senk Funktion

Charnière inférieure levante



Installazione ad altezza libera

free-standing installation

Installation in freier Höhe

Installation en hauteur libre





Le guarnizioni magnetiche sono nascoste all'interno dei montanti di battuta

The magnetic gaskets are hidden inside the vertical profiles

Die magnetischen Dichtungen sind im Inneren der Senkrechtenprofile versteckt

Les joints magnétiques sont cachés à l'intérieur des montants



Profili a parete regolabili

Adjustable wall profiles

Verstellbare Wandanschlussprofile

Profilés au mur réglables



Doppia guarnizione inferiore

Double bottom gasket

Doppelte Bodendichtung

Joint double au sol



Modulo drenaggio acqua

Water drainage module

Wasserentwässerungsmodul

Module d'évacuation des eaux

Applicazioni Applications - Anwendungen - Applications

Vanity set 1

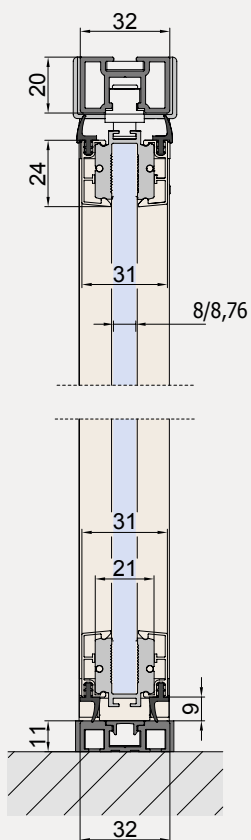
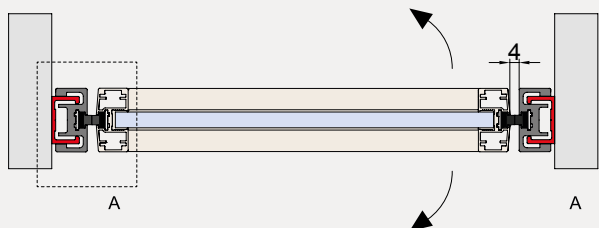
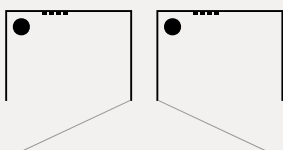

Vanity set 2

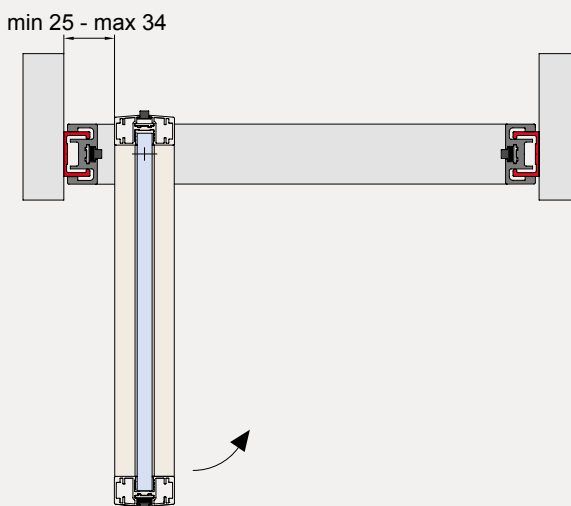
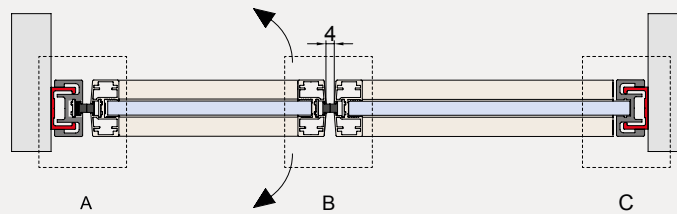
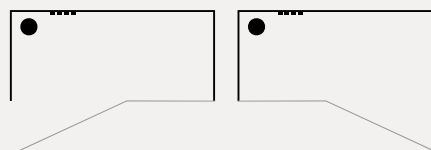

Porta battente
Hinged door
Drehtür
Porte battentes

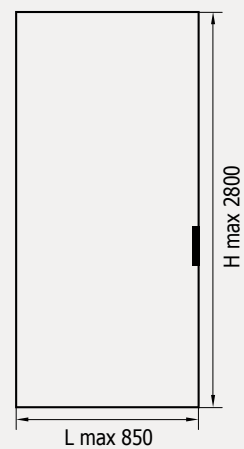



Vanity
Metalglas App

Vanity set 3

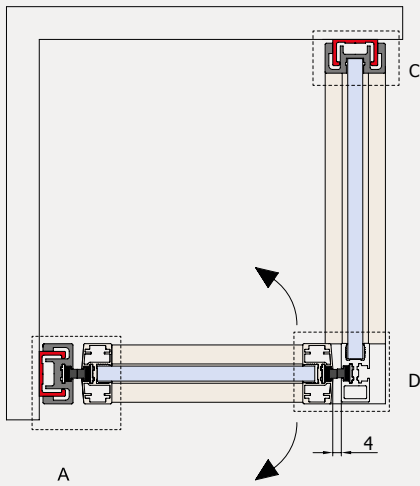
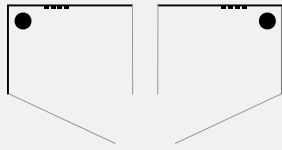

Vanity set 4

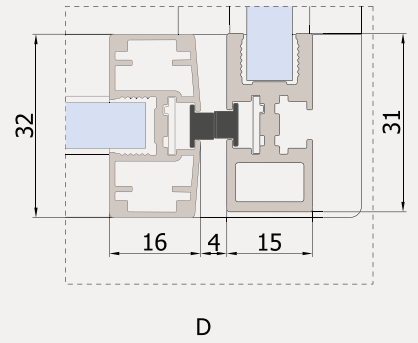
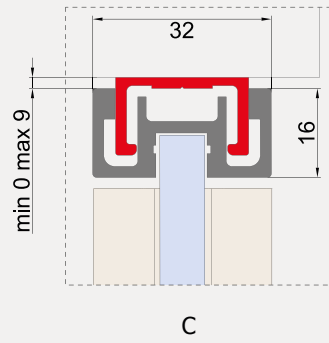
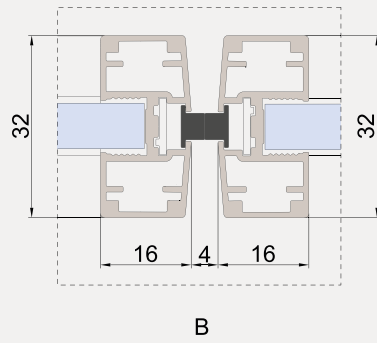
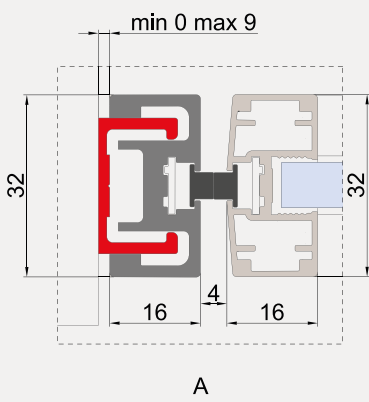
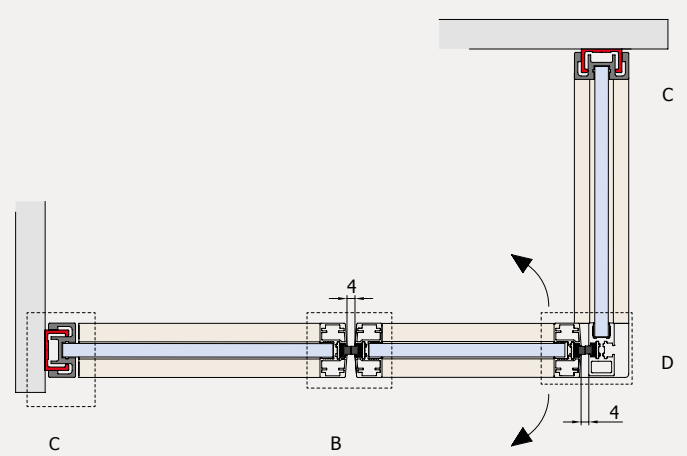
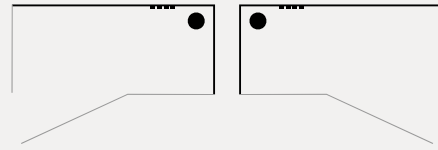
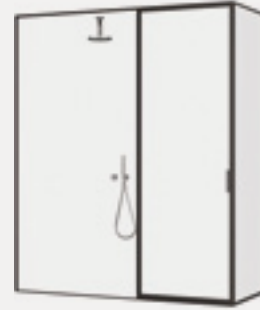

Applicazioni Applications - Anwendungen - Applications

Vanity set 5

Vanity set 6

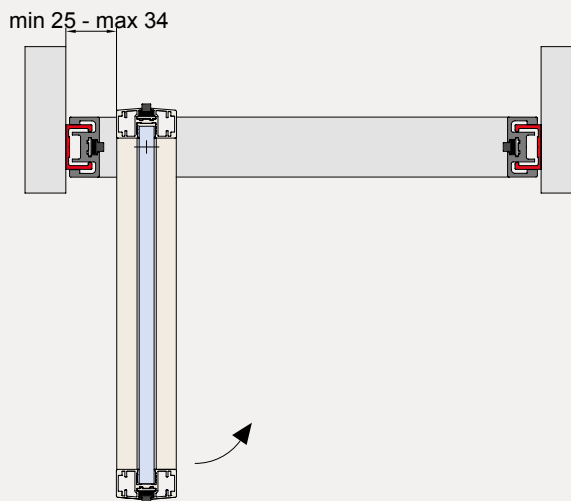
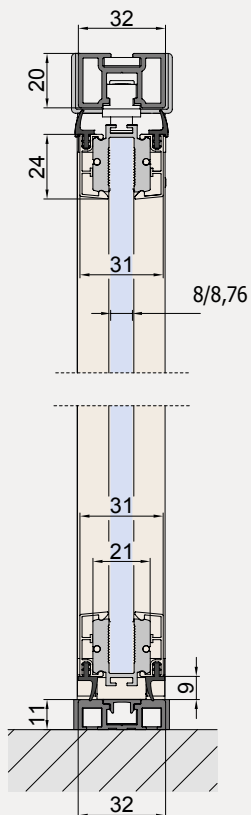
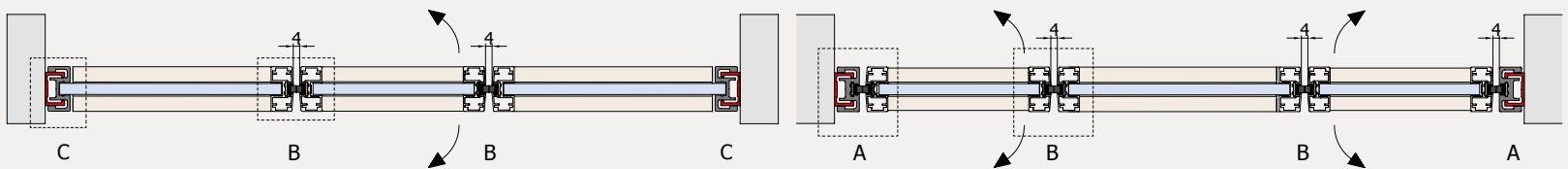
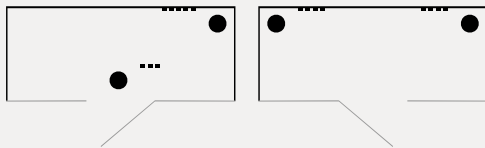
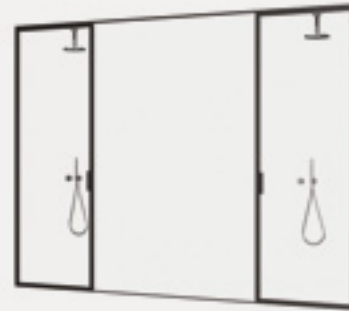
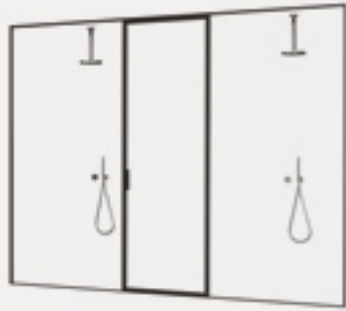

Porta battente
Hinged door
Drehtür
Porte battentes

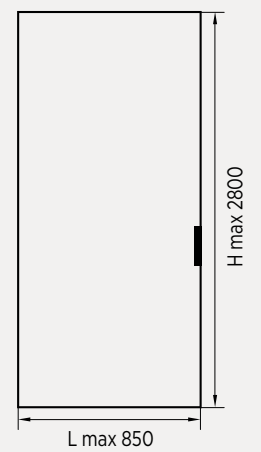



Vanity
Metalglas App

Vanity set 7

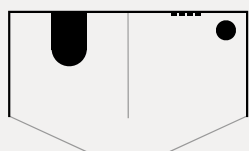

Vanity set 8

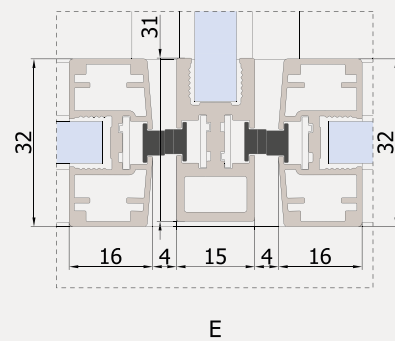
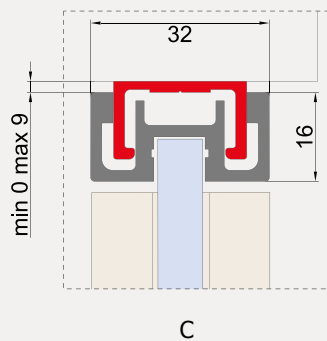
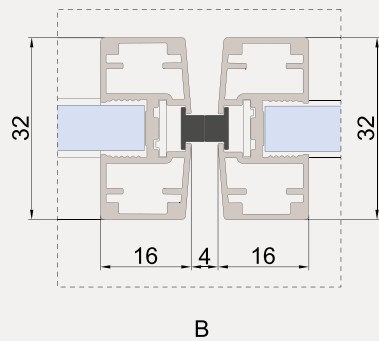
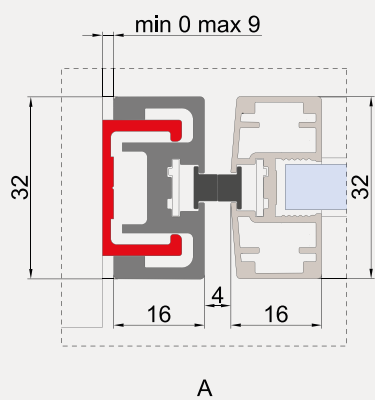
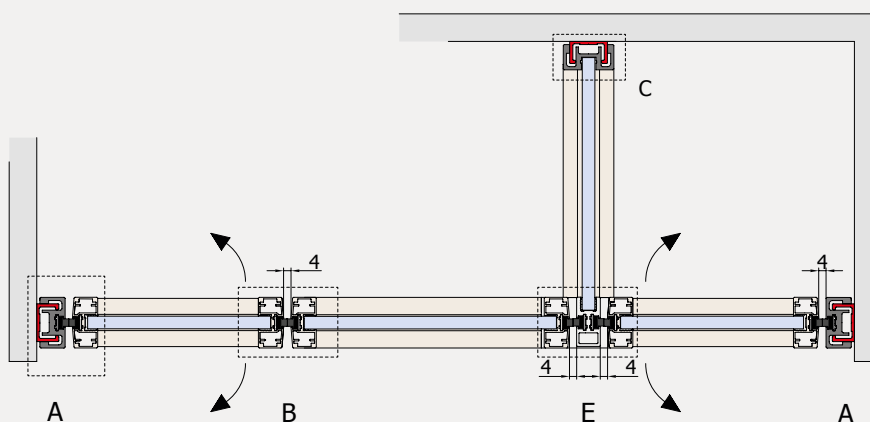
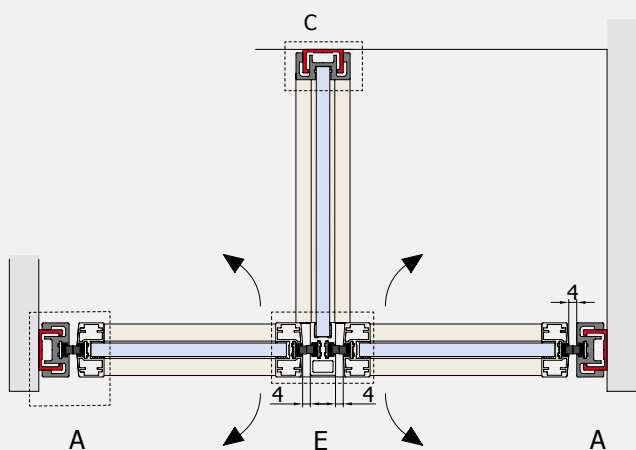
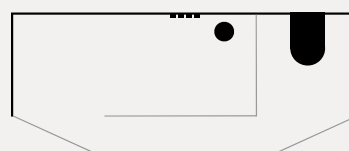

Gamma finiture
 Finishing range
 Oberflächen programm
 Gamme de finition



CR
Cromo Lucido
 Polished Chrome
 Chrom Glänzend
 Chromé Poli

Finitura ottenuta
 mediante ossidazione
 anodica
 Finish by anodic
 oxidation
 Oberfläche durch
 anodische Oxidation
 Finition par oxydation

IX
Effetto Inox
Satinato
 Inox Effect
 Inox Effekt
 Effet Inox

Finitura ottenuta
 mediante ossidazione
 anodica
 Finish by anodic
 oxidation
 Oberfläche durch
 anodische Oxidation
 Finition par oxydation

NO
Nero Opaco
 Matt Black
 Schwarz Matt
 Noir Mat

Finitura ottenuta
 mediante ossidazione
 anodica
 Finish by anodic
 oxidation
 Oberfläche durch
 anodische Oxidation
 Finition par oxydation

CF
Canna di Fucile
 Gunmetal Grey
 Tief Schwarz Matt
 Gris Acier

Finitura ottenuta
 mediante ossidazione
 anodica
 Finish by anodic
 oxidation
 Oberfläche durch
 anodische Oxidation
 Finition par oxydation

BV
Bronzo Scuro
 Dark Bronze
 Dunkelbraun
 Brun Foncé

Finitura ottenuta
 mediante
 verniciatura.
 Finish by painting
 Oberfläche durch
 Lackierung
 Finition obtenue
 par peinture

I colori riprodotti sono indicativi e possono differire leggermente da quelli reali.
 The colours reproduced are indicative and may slightly differ from the original ones.
 Die Farbgebung der Bilder können vom dargestellten Original leicht abweichen.
 Les couleurs reproduites sont purement indicatives et peuvent différer légèrement de celles originales.



OL
Ottone Lucido
 Polished Brass
 Messing Poliert
 Laiton Poli

Finitura ottenuta mediante ossidazione anodica
 Finish by anodic oxidation
 Oberfläche durch anodische Oxidation
 Finition par oxydation

OS
Oro Satinato
 Satin Gold
 Gold matt
 Or Satiné

Finitura ottenuta mediante ossidazione anodica
 Finish by anodic oxidation
 Oberfläche durch anodische Oxidation
 Finition par oxydation

RM
Rame Satinato
 Satin Copper
 Kupfer Matt
 Cuivre Satiné

Finitura ottenuta mediante ossidazione anodica
 Finish by anodic oxidation
 Oberfläche durch anodische Oxidation
 Finition par oxydation

BI
Bianco Opaco (RAL 9016)
 Matt White
 Weiss Matt
 Blanc Mat

Finitura ottenuta mediante verniciatura.
 Finish by painting
 Oberfläche durch Lackierung
 Finition obtenue par peinture

Maniglie

Handles - Griffe - Poignées

POR-0400V

Maniglione singolo con biadesivo
 Pc pullhandle with self-adhesive fixing
 Stück Stosgriff selbstklebend
 Poignée de tirage avec fixation adhésive

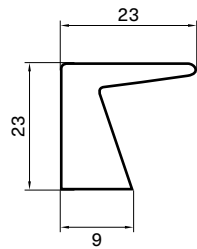

L = 240 mm

SQUARE 15

Paio maniglioni
 Pair pullhandles
 Paar Stosgriffe
 Paire bâtons de maréchal

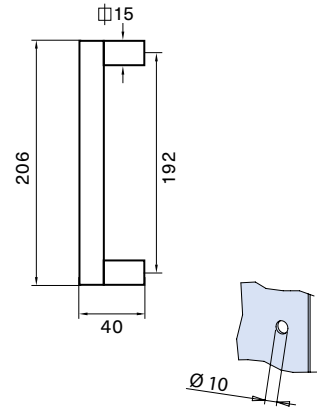

B-196

Coppia pomoli 25x28 mm
 Pair of doorknobs 25x28 mm
 Paar Türknöpfe 25x28 mm
 Paire de boutons 25x28 mm

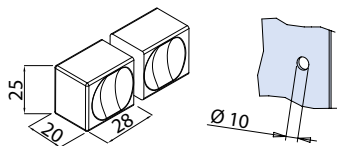

V-024-25

Coppia pomoli Ø 25 mm
 Pair of doorknobs Ø 25 mm
 Paar Türknöpfe Ø 25 mm
 Paire de boutons Ø 25 mm

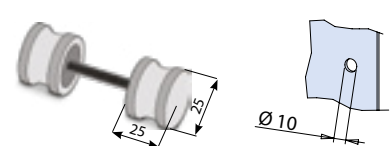

MID-10-INC

Paio maniglie con fissaggio mediante biadesivo
 Pair handles with self-adhesive fixing
 Paar Griffe selbstklebend
 Paire poignées de tirage avec fixation adhésive

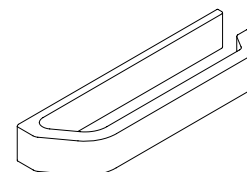
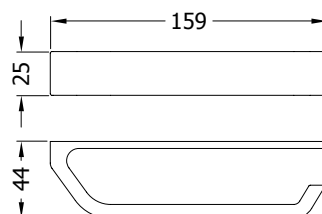



VANITY-SET6

No
Finitura / Finish / Oberfläche
Finition

POR-0400V
Maniglia / Handle / Griff / Poignée

26

Vanity

VANITY-SET6

No
Finitura / Finish / Oberfläche
Finition

POR-0400V
Maniglia / Handle / Griff / Poignée



Metalglas Bonomi s.r.l.

Via Montini, 106/A

25065 Lumezzane S.A. (Brescia) Italy

Ph. +39 030 829910 - Fax +39 030 8920970

www.metalglas.it - info@metalglas.it

