

# WALL2-DIV100 PARETE + PORTA BATTENTE DIVINA

SET COMPLETO CON PROFILO A SCATTO, STIPITE E PORTA BATTENTE INTELAIATA

COMPLETE SET WITH CLIP-ON PROFILE, DOOR JAMB AND FRAMED HINGED DOOR - KOMPLETTSET MIT KLIPSPROFIL, ZARGE UND GERAHMTE DREHTÜR

SET	= TP-150	+ DIV-100	+ DIV-050	+ DIV-052	+ DIV-208 (optional)	+ DIV-204 (optional)
	Stipite Door jamb Zarge	Anta intelaiata Hinged framed panel Gerahmte Dreh-Tür	Profilo a scatto Clip-on profile Klipsprofil	Profilo superiore a "U" Top "U" channel Oberes "U" Profil	Profilo H H profile H Profil	Listello Cross profile Querprofil

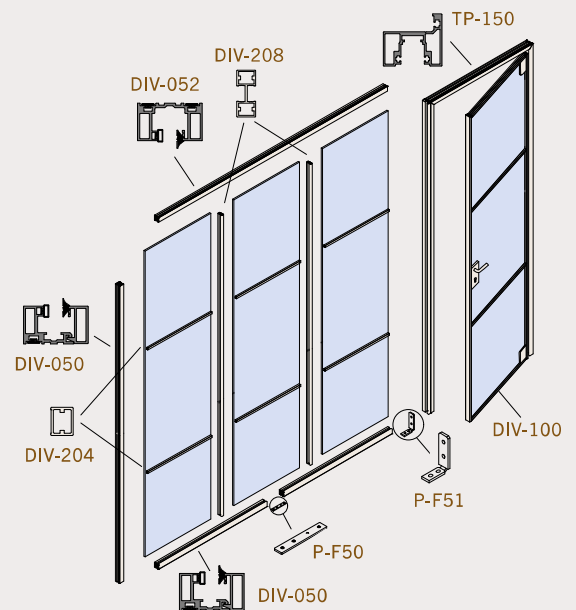
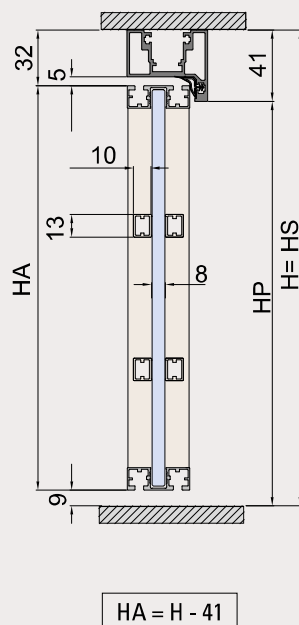
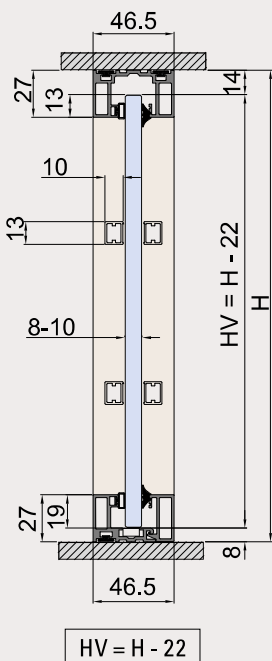
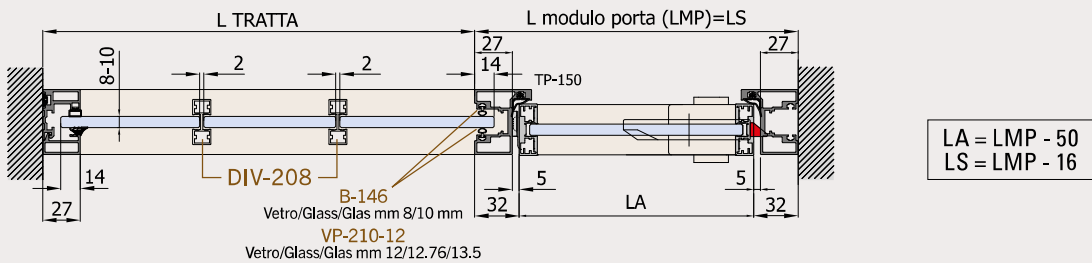
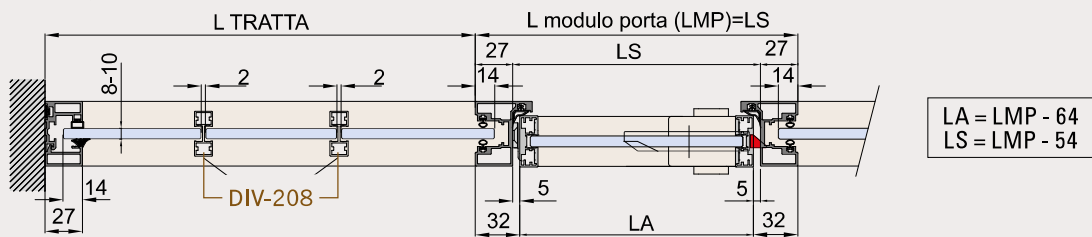
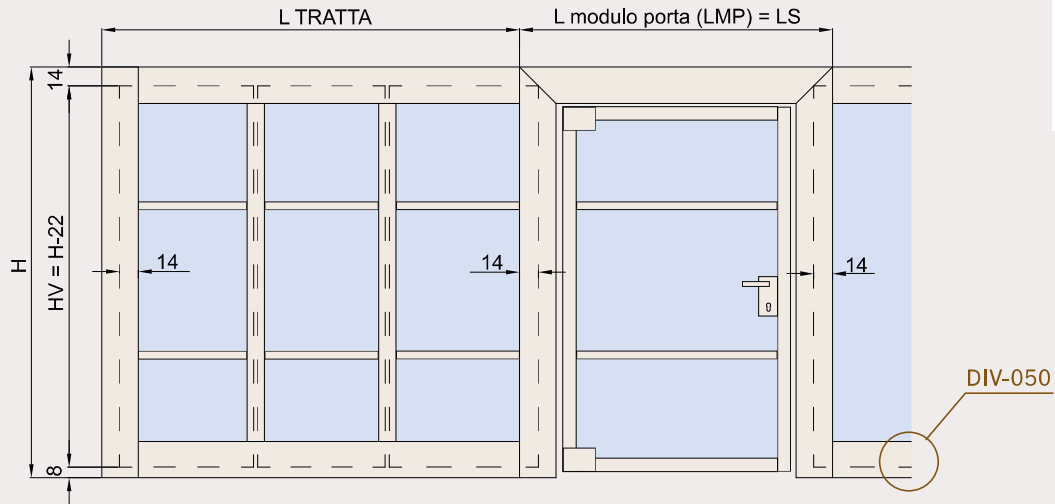

8 (Porta/Door/Tür) 8/10 (Vetro fisso/Fixed glass/Festverglasung)

xme658c

# DIV-050 + DIV-052

PROFILI PER FISSI - PROFILES FOR FIXED PANELS - PROFILE FÜR FESTVERGLASUNGEN



MY METALGLAS

Componi la tua anta per quantificare i traversini da ordinare  
 Configure your panel to calculate the cross profiles  
 Konfigurieren Sie Ihre Tür und berechnen Sie automatisch die Querprofile



**DIV-050**  
 Profilo a scatto per vetro fisso  
 Clip-on profil for fixed panel  
 Klipsprofil für Festverglasung

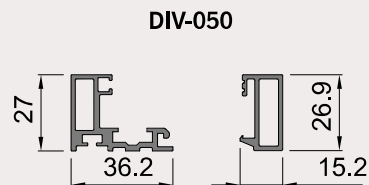

**DIV-052**

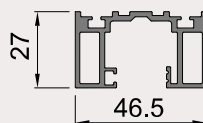

**DIV-052**  
 Profilo superiore a "U"  
 Top "U" channel  
 Oberes "U" Profil

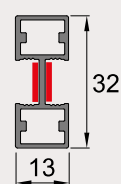
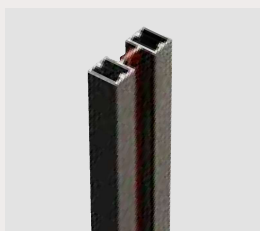
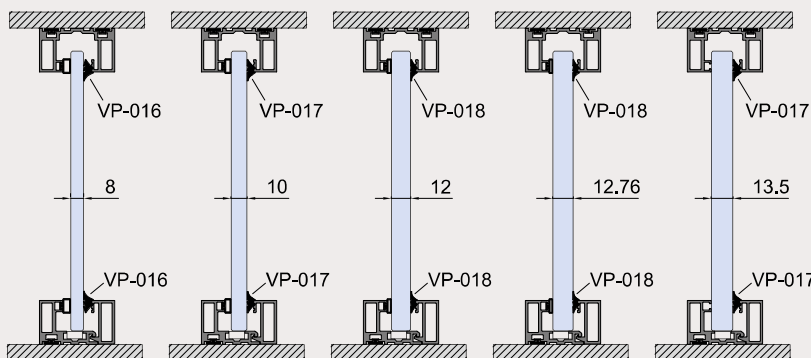
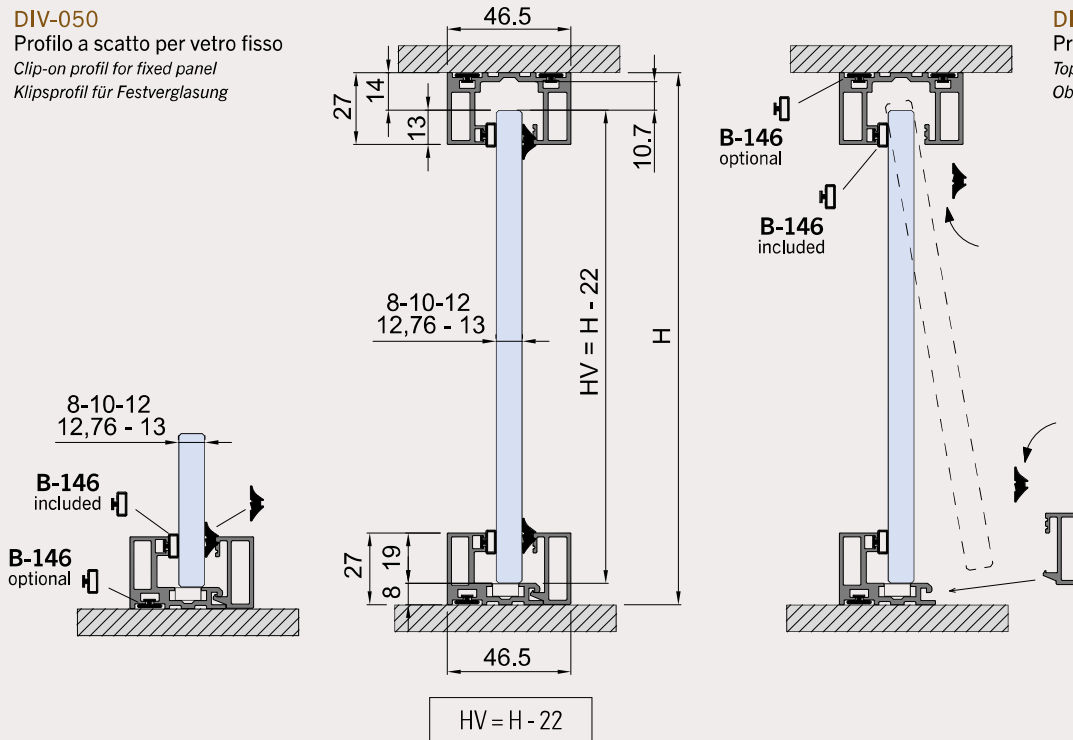

**DIV-208**  
 Profilo "H" vetro-vetro  
 "H" profile Glass-Glass  
 "H" Profil Glas-Glas

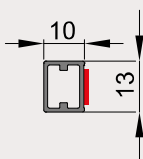

**DIV-204**  
 Traversino  
 Cross profile  
 Querprofil



P-F51

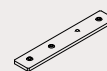

P-F50