

1 FORTE STRONG / STARK

UNIVERSITÀ DEGLI STUDI DI BRESCIA
DICATAM DIPARTIMENTO DI INGEGNERIA CIVILE, ARCHITETTURA,
TERRITORIO, AMBIENTE E DI MATEMATICA
LABORATORIO PROVE MATERIALI «PIETRO PISA»

UNI11678:2017

SET	Vetro mm Glass mm Glas mm	L	H da piano calpestio above floor level ab begehbaren Fläche	Testato spinta Test side force Getestete Seitenkraft	Classe Class ITA Klasse ITA	UNI11678:2017
BP-320 / BP-370	6+6+0,76 pvb	1400 mm	1200 mm	150 Kg	1	1 kN/m = 100kg/m
	6+6+0,76 pvb	1400 mm	1200 mm	300 Kg	2	2 kN/m = 200kg/m

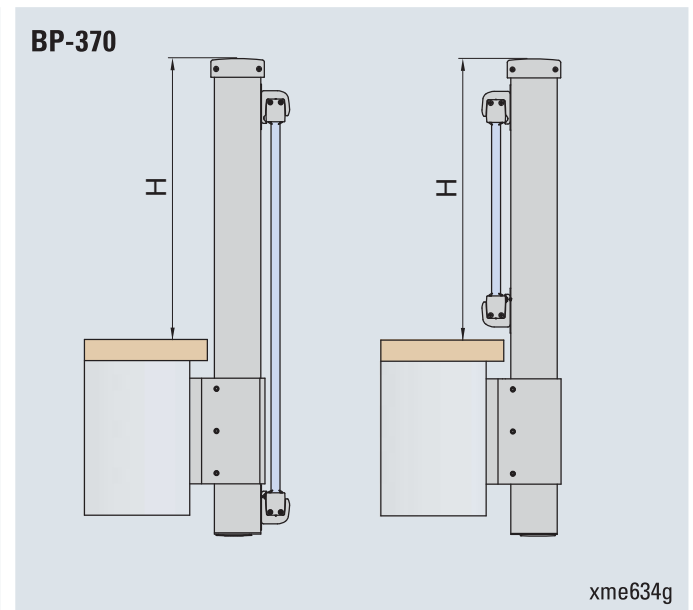
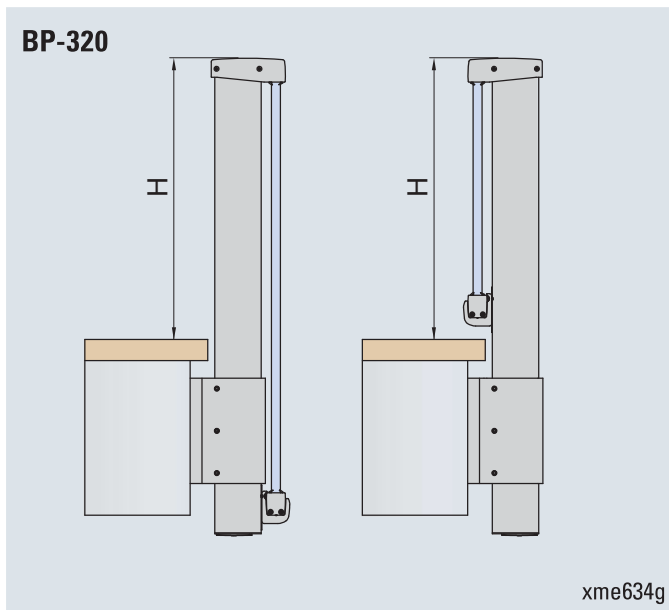

SET	Vetro mm Glass mm Glas mm	L	H da piano calpestio above floor level ab begehbaren Fläche	Testato spinta Test side force Getestete Seitenkraft	Classe Class ITA Klasse ITA	UNI11678:2017
BP-300 / BP-350	6+6+0,76 pvb	1500 mm	1200 mm	150 Kg	1	1 kN/m = 100kg/m
	6+6+0,76 pvb	1500 mm	1200 mm	300 Kg	2	2 kN/m = 200kg/m

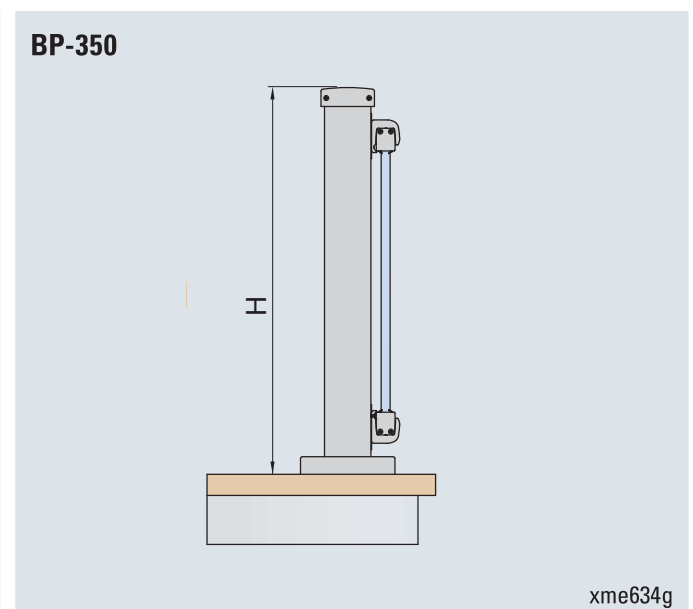
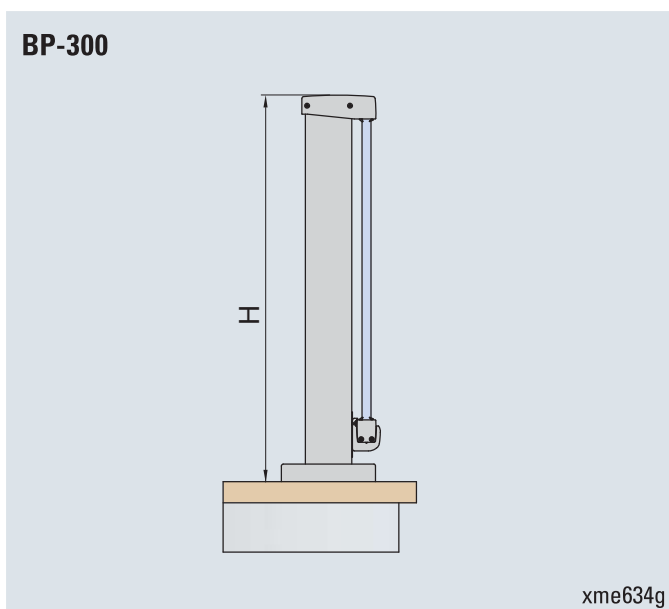

STRIPE



Fissaggio a pavimento tramite staffa con saetta in acciaio che ha superato le prove di spinta senza difficoltà.

Facilità di montaggio staffa al profilo palo (a cura del cliente).

Fixing to the floor by a reinforced steel bracket, which passed loading tests without difficulty. Easy assembly to the post profile (by the customer).

Befestigung am Boden mittels einer verstärkten Halterung, die die Belastungstests problemlos bestanden hat.

Einfache Montage der Halterung am Pfostenprofil (hauseitig).



Norma UNI 11676 max flessione 100 mm

UNI 11676 Norm max deflection 100 mm

UNI 11676 max 100 mm Durchbiegung

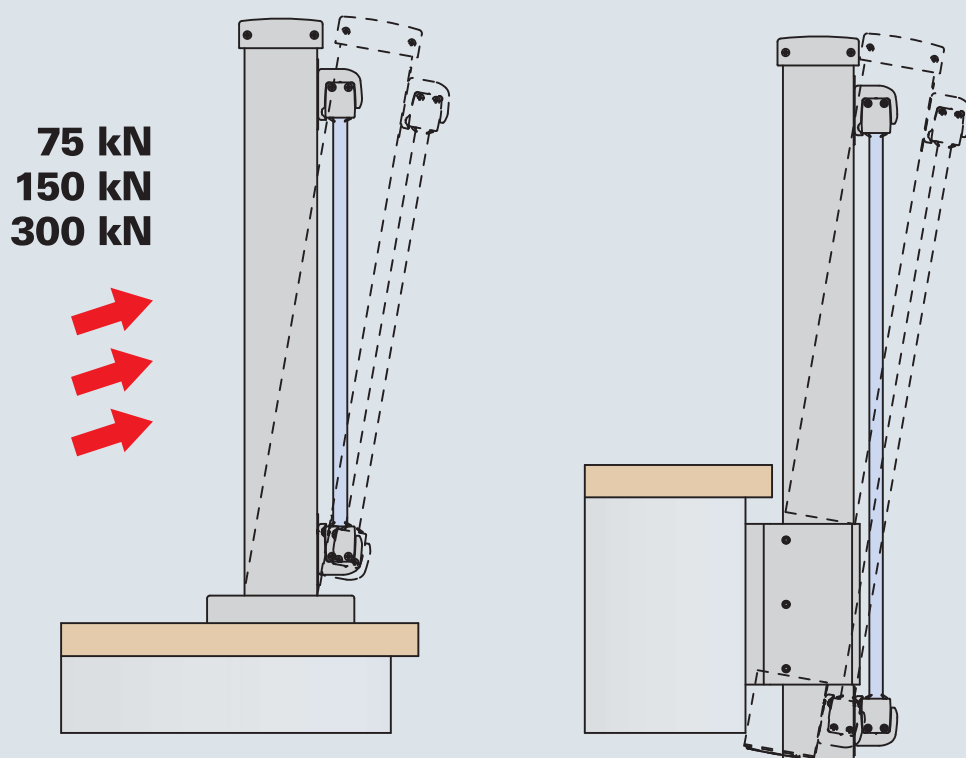

STRIPE

STRIPE COLORI

STRIPE COLORS

STRIPE OBERFLÄCHEN

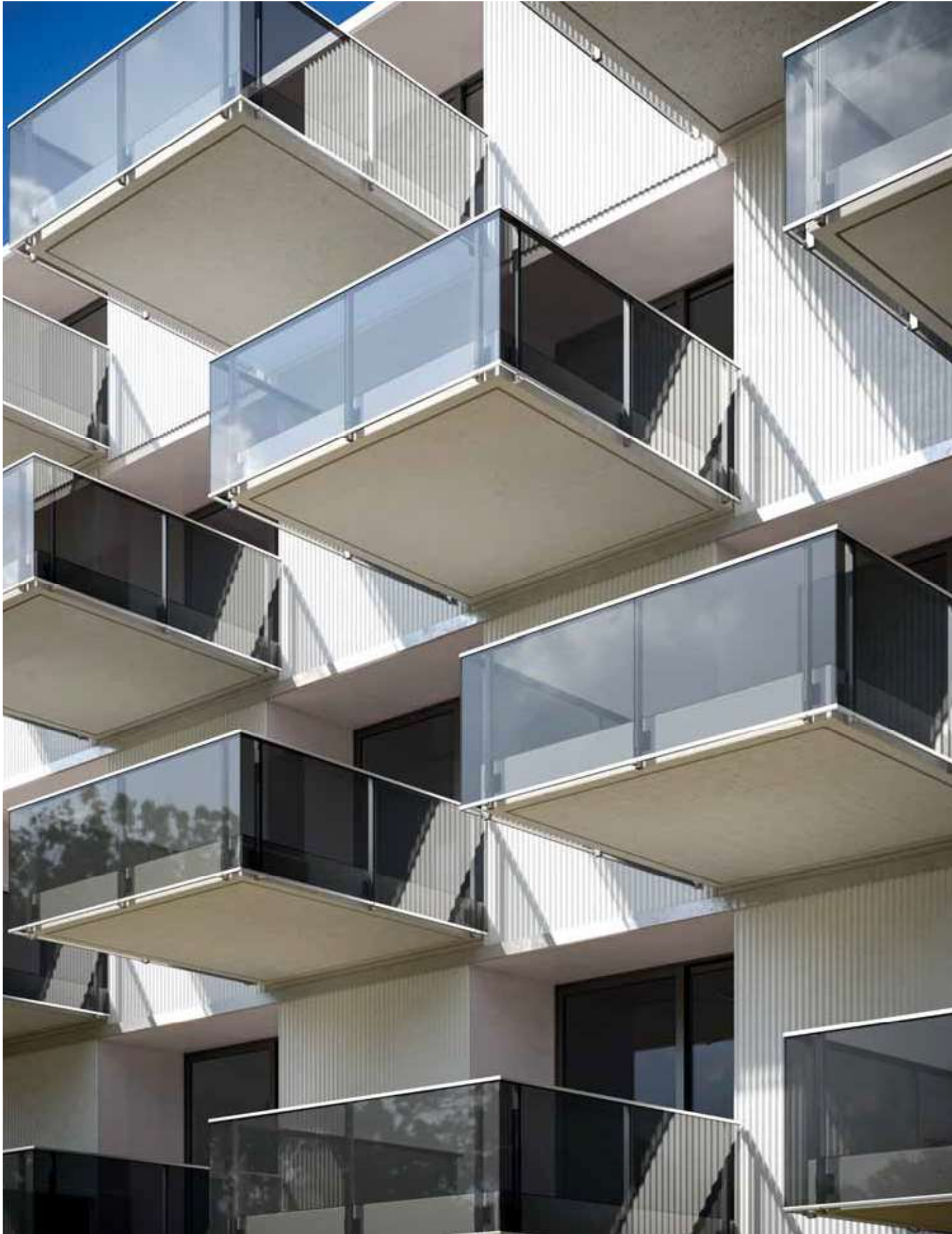

STRIPE



STRIPE



Colore standard consegna veloce: AN alluminio anodizzato argento
Standard color quick delivery: AN silver anodized aluminum
Standard Oberfläche schnelle Lieferung: AN silberfarbiges eloxiertes Aluminium



Altri colori a richiesta
Other colors on request
Andere Oberflächen auf Anfrage

BP-370

VERSIONE CON CORRIMANO INDIPENDENTE, FISSAGGIO LATERALE, PER VETRO LATO ESTERNO
 VERSION WITH INDEPENDENT HANDRAIL, SIDE INSTALLATION, FOR EXTERNAL GLASS
 AUSFÜHRUNG MIT SEPARATEM HANDLAUF, SEITENMONTAGE, FÜR GLAS AUSSENSEITE VON PFOSTEN

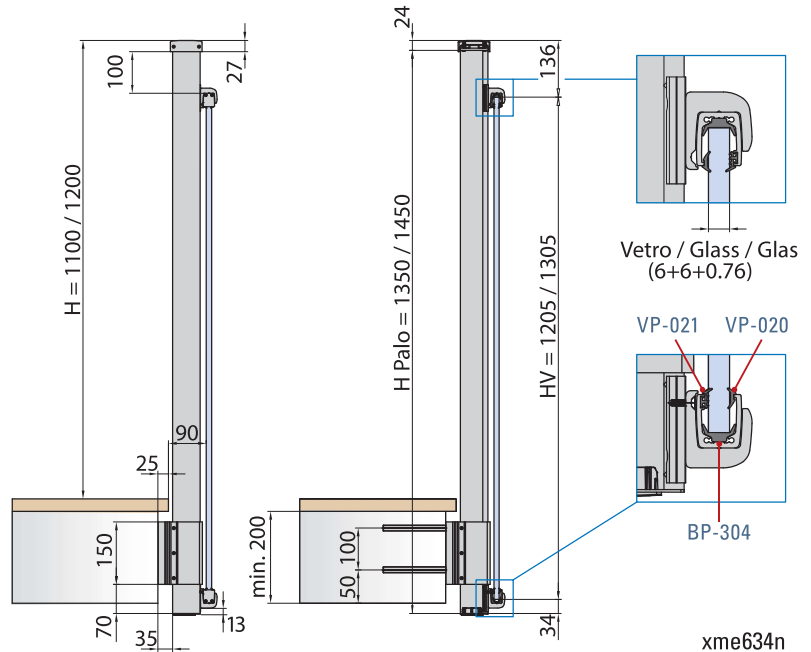

Set palo, fissaggio laterale. H=1100 mm/1200 mm.
 Per vetro 6+6+0.76. Profili corrimano e fermavetro non inclusi.
 Set side installation post. H=1100 mm/1200 mm.
 For glass 6+6+0.76. Handrail and glass stop profiles not included.
 Set Pfosten, Seitenmontage. H=1100 mm/1200 mm.
 Für Glas 6+6+0.76. Handlauf und Glasleiste Profile nicht enthalten.

HV = Altezza vetro / Glass height / Glashöhe
 H Palo = Altezza palo / Post height / Pfostenhöhe

PAGINE TECNICHE / TECHNICAL PAGES / TECHNISCHE SEITEN ▶ 85

COMPONENTI / COMPONENTS / EINZELTEILE ▶ 86-87

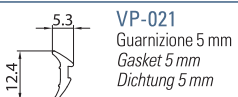
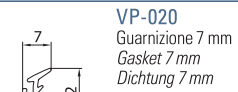
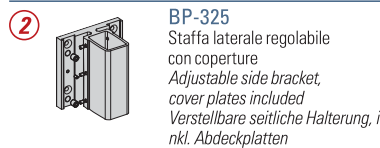
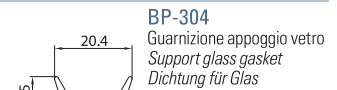
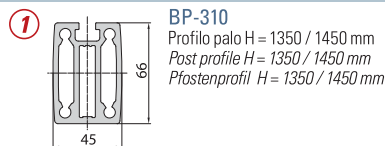
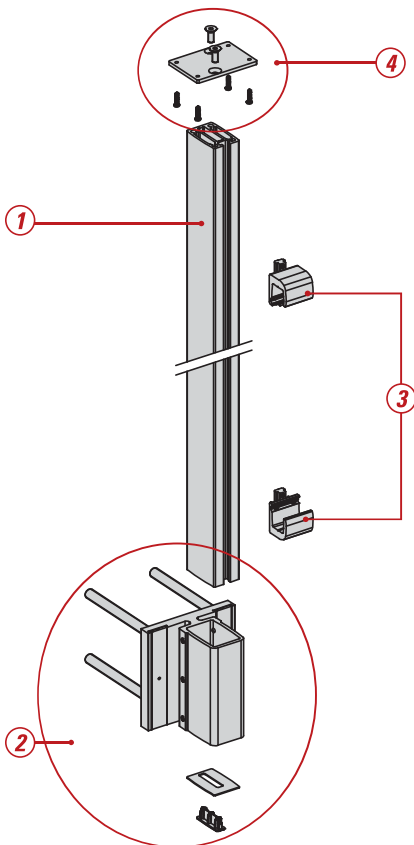

NON INCLUSI NEL SET / NOT INCLUDED IN SET / NICHT IM SET ENTHALTEN

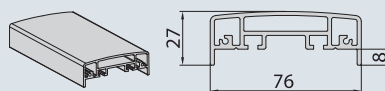

xme634a/d/e



STRIPE

BP-370

VERSIONE CON CORRIMANO INDIPENDENTE, FISSAGGIO LATERALE, PER VETRO LATO INTERNO
VERSION WITH INDEPENDENT HANDRAIL, SIDE INSTALLATION, FOR INTERNAL GLASS
AUSFÜHRUNG MIT SEPARATEM HANDLAUF, SEITENMONTAGE, FÜR GLAS INNENSEITE VON PFOSTEN

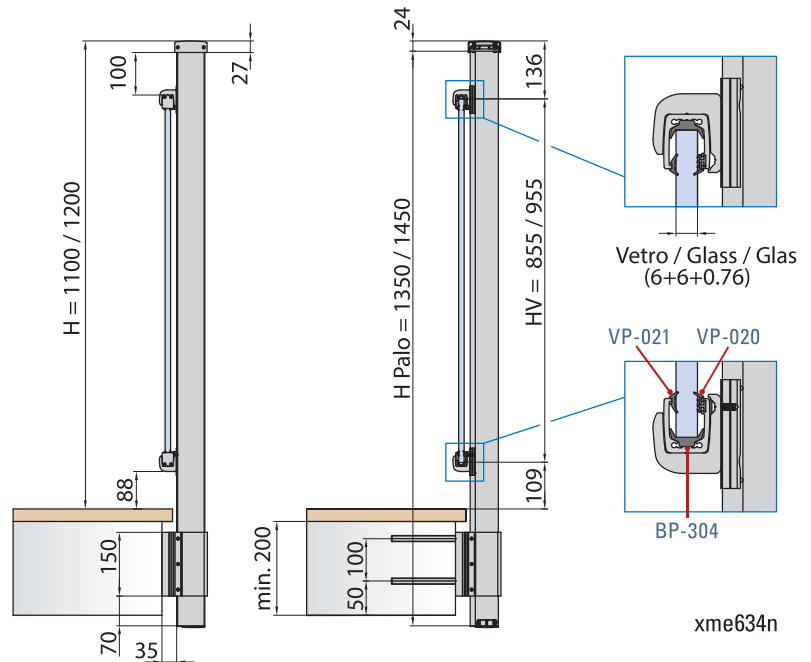

Set palo, fissaggio laterale. H=1100 mm/1200 mm.
Per vetro 6+6+0.76. Profili corrimano e fermavetro non inclusi.
Set side installation post. H=1100 mm/1200 mm.
For glass 6+6+0.76. Handrail and glass stop profiles not included.
Set Pfosten, Seitenmontage. H=1100 mm/1200 mm.
Für Glas 6+6+0.76. Handlauf und Glasleiste Profile nicht enthalten.

HV = H - 121
H Palo = H - 121
HV = Altezza vetro / Glass height / Glashöhe
H Palo = Altezza palo / Post height / Pfostenhöhe

PAGINE TECNICHE / TECHNICAL PAGES / TECHNISCHE SEITEN ▶ 85

COMPONENTI / COMPONENTS / EINZELTEILE ▶ 86-87

	<p>BP-310 Profilo palo H = 1350 / 1450 mm Post profile H = 1350 / 1450 mm Pfostenprofil H = 1350 / 1450 mm</p>	<p>BP-304 Guarnizione appoggio vetro Support glass gasket Dichtung für Glas</p>
	<p>BP-325 Staffa laterale regolabile con coperture Adjustable side bracket, cover plates included Verstellbare seitliche Halterung, inkl. Abdeckplatten</p>	<p>VP-020 Guarnizione 7 mm Gasket 7 mm Dichtung 7 mm</p>
	<p>BP-306 Morsetto di sostegno per profilo fermavetro Connection clamp for glass stop profile Klemmverbinder für Glasleiste Profil 2 pcs</p>	<p>VP-021 Guarnizione 5 mm Gasket 5 mm Dichtung 5 mm</p>
	<p>BP-307 Piastra di connessione palo/corrimano Post/handrail connection plate Verbindungsplatte Pfosten/Handlauf</p>	

NON INCLUSI NEL SET / NOT INCLUDED IN SET / NICHT IM SET ENTHALTEN

	<p>BP-351 Profilo corrimano escluse guarnizioni Handrail profile, gaskets not included Handlauf Profil, Dichtungen nicht enthalten L = 3000 / L = 6000</p>	
	<p>BP-303 Profilo fermavetro, escluse guarnizioni Glass stop profile, gaskets not included Glasleiste Profil, Dichtungen nicht enthalten L = 3000 / L = 6000</p>	

xme634a/b/d/e



STRIPE

SEZIONE TECNICA - TECHNICAL PAGES - TECHNISCHE SEITEN

ESEMPI DI DISTANZA MASSIMA TRA I PALI

EXAMPLES OF MAXIMUM DISTANCE BETWEEN POSTS

BEISPIELEN VON MAXIMALEM ABSTAND ZWISCHEN PFOSTEN

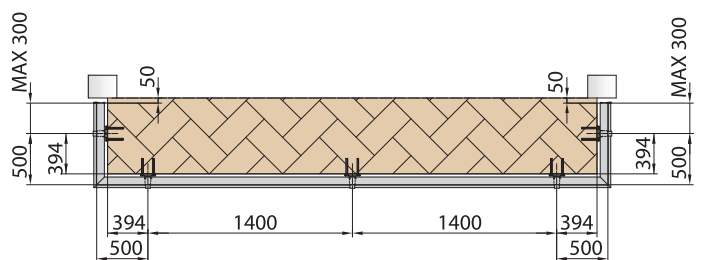
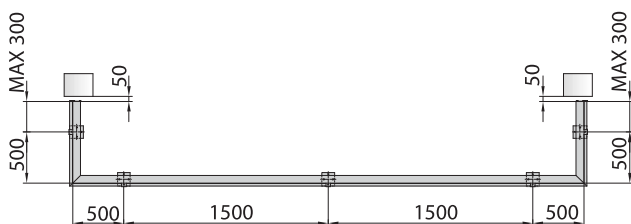
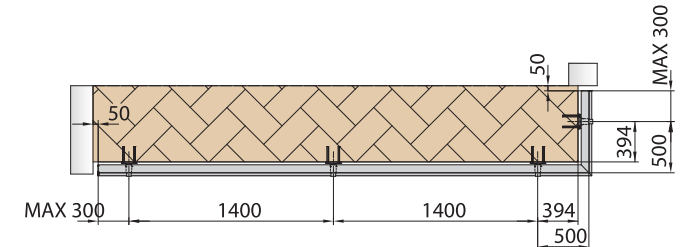
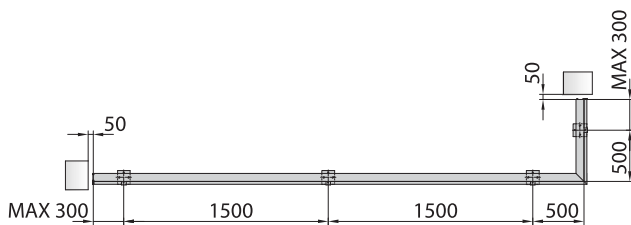
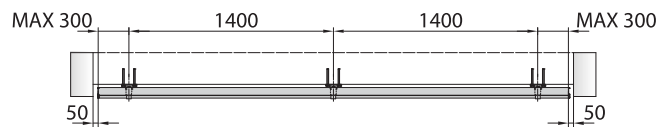
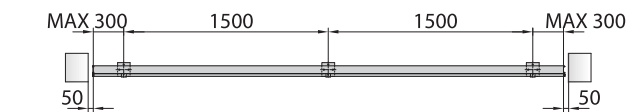
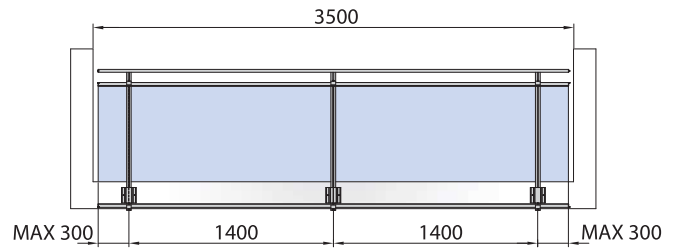
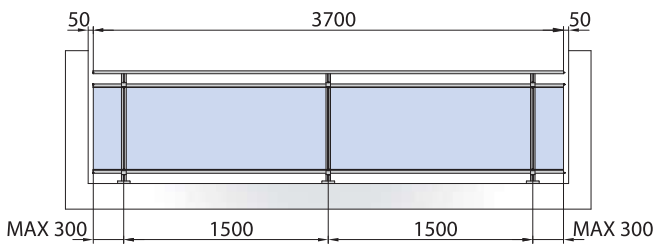

FISSAGGIO A PAVIMENTO
 FLOOR INSTALLATION
 BODENMONTAGE

FISSAGGIO LATERALE
 SIDE INSTALLATION
 SEITENMONTAGE

STRIPE

COMPONENTI

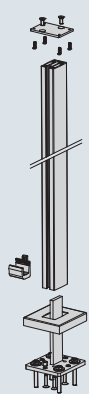
COMPONENTS EINZELTEILE

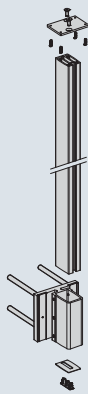
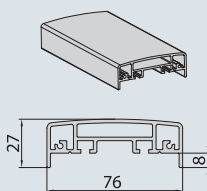
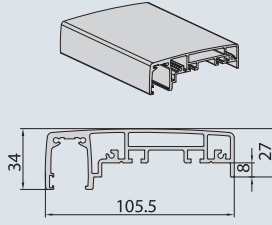
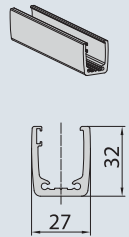
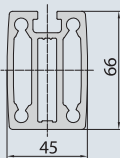
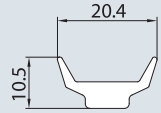
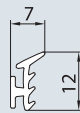
	<p>BP-300 Set palo composto di staffa con saetta in acciaio, fissaggio a pavimento, morsetto vetro, tappi e guarnizioni. <i>Set post for floor installation, reinforced steel bracket, glass clamp, endcaps and gasket included.</i> Set Pfosten, Bodenmontage, inklusive verstärkten Halterung, Glasklemme, Endkappe und Dichtungen.</p> <p>H = 1100 mm / 1200 mm</p> <p style="text-align: right;">xme634b</p>		<p>BP-320 Palo composto di staffa con saetta in acciaio, fissaggio laterale, morsetto vetro, tappi e guarnizioni. <i>Set post for side installation, reinforced steel bracket, glass clamp endcaps and gaskets included.</i> Set Pfosten, Seitenmontage, inklusive verstärkten Halterung, Glasklemme, Endkappen und Dichtungen.</p> <p>H = 1100 mm / 1200 mm</p> <p style="text-align: right;">xme634c</p>
	<p>BP-350 Palo composto di staffa con saetta in acciaio, fissaggio a pavimento, morsetto vetro, tappi e guarnizioni. Versione per corrimano indipendente. <i>Set post for floor installation, reinforced steel bracket, glass clamp, endcaps and gasket included.</i> Version for independent handrail. Set Pfosten, Bodenmontage, inklusive verstärkten Halterung, Glasklemme, Endkappe und Dichtungen. Ausführung für separaten Handlauf.</p> <p>H = 1100 mm / 1200 mm</p> <p style="text-align: right;">xme634a</p>		<p>BP-370 Palo composto di staffa con saetta in acciaio, fissaggio laterale, morsetto vetro, tappi e guarnizioni. Versione per corrimano indipendente. <i>Set post for side installation, reinforced steel bracket, glass clamp endcaps and gaskets included.</i> Version for independent handrail. Set Pfosten, Seitenmontage, inklusive verstärkten Halterung, Glasklemme, Endkappen und Dichtungen. Ausführung für separaten Handlauf.</p> <p>H = 1100 mm / 1200 mm</p> <p style="text-align: right;">xme634a</p>
<p style="writing-mode: vertical-rl; transform: rotate(180deg);">STRIPE</p> 	<p>BP-351 Corrimano per pali BP-350 / BP-370. Versione per corrimano indipendente. <i>Handrail for posts BP-350 / BP-370.</i> Version for independent handrail. Handlauf für Pfosten BP-350 / BP-370. Ausführung für separaten Handlauf.</p> <p>L = 3000 / 6000 mm</p> <p style="text-align: right;">xme634d</p>		<p>BP-301 Corrimano per pali BP-300 / BP-320. <i>Handrail for posts BP-300 / BP-320.</i> Handlauf für Pfosten BP-300 / BP-320.</p> <p>L = 3000 / 6000</p> <p style="text-align: right;">xme634d</p>
	<p>BP-303 Profilo fermavetro, escluse guarnizioni. <i>Glass stop profile, gaskets not included.</i> Glasleiste Profil, Dichtungen nicht enthalten</p> <p>L = 3000 / 6000 mm</p> <p style="text-align: right;">xme634d</p>		<p>BP-310 Profilo palo. <i>Post profile.</i> Pfostenprofil.</p> <p>H = 1065 / 1165 / 1350 / 1450 mm</p> <p style="text-align: right;">xme634d</p>
	<p>BP-304 Guarnizione appoggio vetro. <i>Support glass gasket.</i> Dichtung für Glas.</p> <p style="text-align: right;">xme634e</p>		<p>VP-020 Guarnizione 7 mm. <i>Gasket 7 mm.</i> Dichtung 7 mm.</p> <p style="text-align: right;">xme634e</p>

COMPONENTI

COMPONENTS

EINZELTEILE

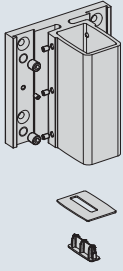
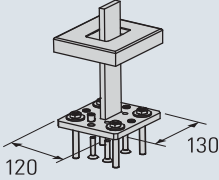
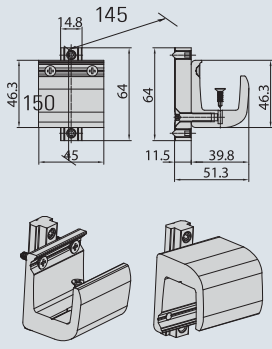
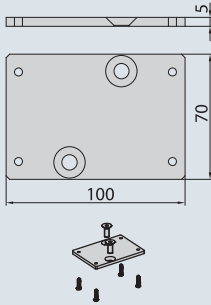
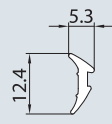
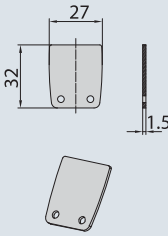
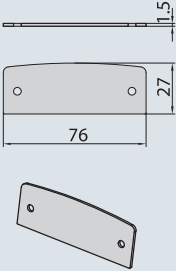
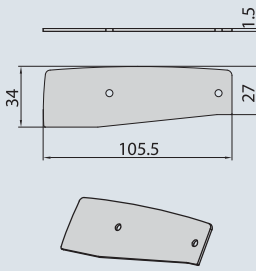
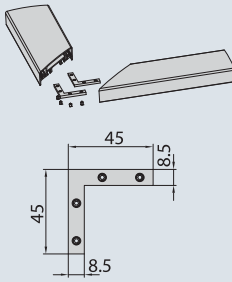
	<p>BP-325 Staffa laterale regolabile con coperture. <i>Adjustable side bracket, cover plates included.</i> Verstellbare seitliche Halterung, inkl. Abdeckplatten.</p>		<p>BP-305 Staffa a pavimento regolabile compresa di coperture. <i>Adjustable floor bracket, cover plates included.</i> Verstellbare Bodenhalterung, inklusive Abdeckplatten.</p>
	<p>BP-306 Morsetto di sostegno per profilo fermavetro. <i>Connection clamp for glass stop profile.</i> Klemmverbinder für Glasleiste Profil.</p>		<p>BP-307 Piastra di connessione palo/corrimano. <i>Post/handrail connection plate.</i> Verbindungsplatte Pfosten/Handlauf.</p>
	<p>VP-021 Guarnizione 5 mm. <i>Gasket 5 mm.</i> Dichtung 5 mm.</p>		<p>BP-311 Tappo per corrimano BP-303. <i>Endcap for handrail BP-303.</i> Endkappe für Handlauf BP-303.</p>
	<p>BP-309 Tappo per corrimano BP-351. <i>Endcap for handrail BP-351.</i> Endkappe für Handlauf BP-351.</p>		<p>BP-308 Tappo per corrimano BP-301. <i>Endcap for handrail BP-301.</i> Endkappe für Handlauf BP-301.</p>
	<p>P-F44 Kit di due staffe angolari. <i>Set corner installation brackets.</i> Set Eckbefestigungswinkel.</p>		



STRIPE