

**1** **FORTE**  
**STRONG / STARK**

UNIVERSITÀ DEGLI STUDI DI BRESCIA  
DICATAM DIPARTIMENTO DI INGEGNERIA CIVILE, ARCHITETTURA,  
TERRITORIO, AMBIENTE E DI MATEMATICA  
LABORATORIO PROVE MATERIALI «PIETRO PISA»

**UNI11678:2017**

SET	Vetro mm Glass mm Glas mm	L	H da piano calpestio above floor level ab begehbaren Fläche	Testato spinta Test side force Getestete Seitenkraft	Classe Class ITA Klasse ITA	<b>UNI11678:2017</b>
<b>BP-320 / BP-370</b>	6+6+0,76 pvb	1400 mm	1200 mm	150 Kg	1	1 kN/m = 100kg/m
	6+6+0,76 pvb	1400 mm	1200 mm	300 Kg	2	2 kN/m = 200kg/m

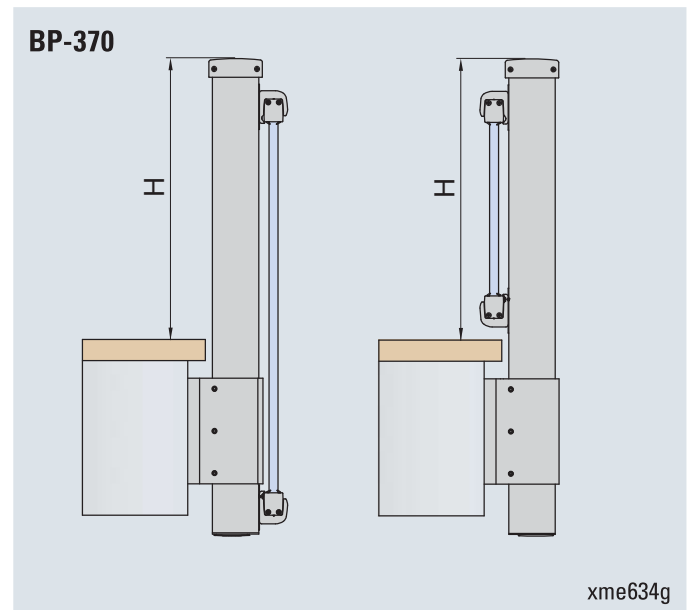
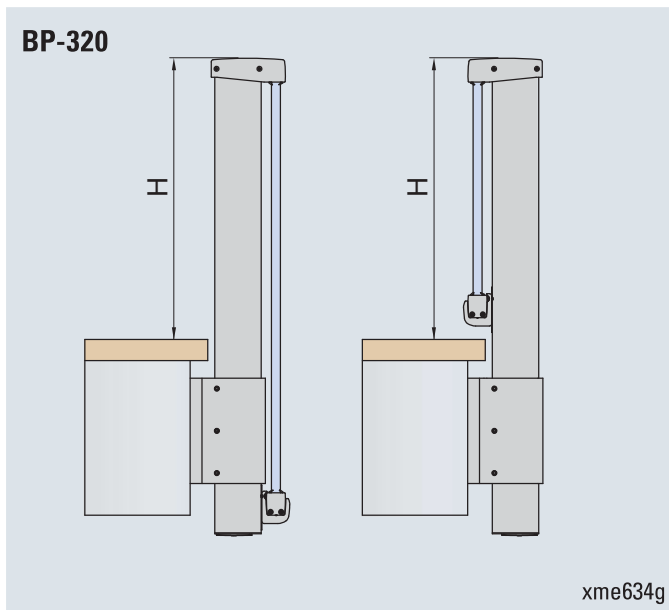

SET	Vetro mm Glass mm Glas mm	L	H da piano calpestio above floor level ab begehbaren Fläche	Testato spinta Test side force Getestete Seitenkraft	Classe Class ITA Klasse ITA	<b>UNI11678:2017</b>
<b>BP-300 / BP-350</b>	6+6+0,76 pvb	1500 mm	1200 mm	150 Kg	1	1 kN/m = 100kg/m
	6+6+0,76 pvb	1500 mm	1200 mm	300 Kg	2	2 kN/m = 200kg/m

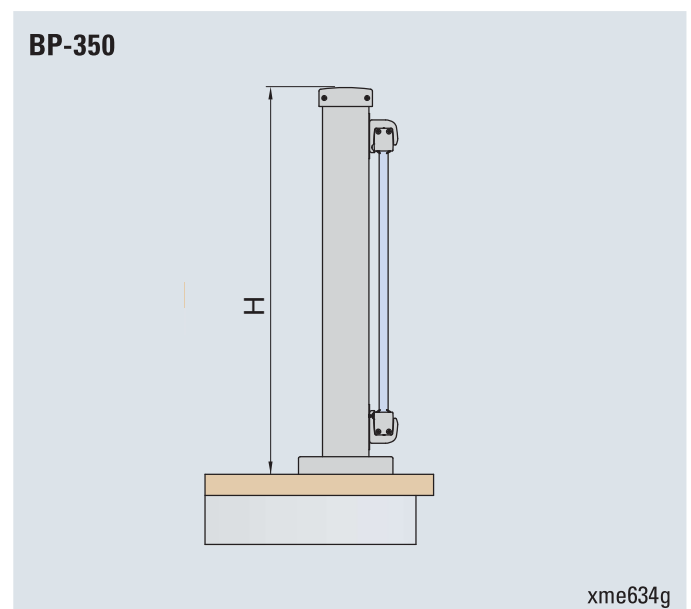
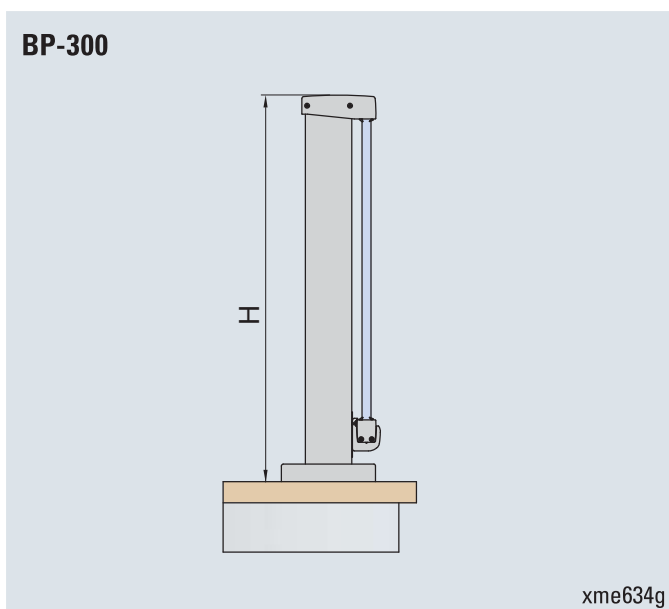

STRIPPE



**Fissaggio a pavimento tramite staffa con saetta in acciaio che ha superato le prove di spinta senza difficoltà.**

**Facilità di montaggio staffa al profilo palo (a cura del cliente).**

*Fixing to the floor by a reinforced steel bracket, which passed loading tests without difficulty.  
Easy assembly to the post profile (by the customer).*

*Befestigung am Boden mittels einer verstärkten Halterung, die die Belastungstests problemlos bestanden hat.*

*Einfache Montage der Halterung am Pfostenprofil (hauseitig).*



**Norma UNI 11676 max flessione 100 mm**

**UNI 11676 Norm max deflection 100 mm**

**UNI 11676 max 100 mm Durchbiegung**

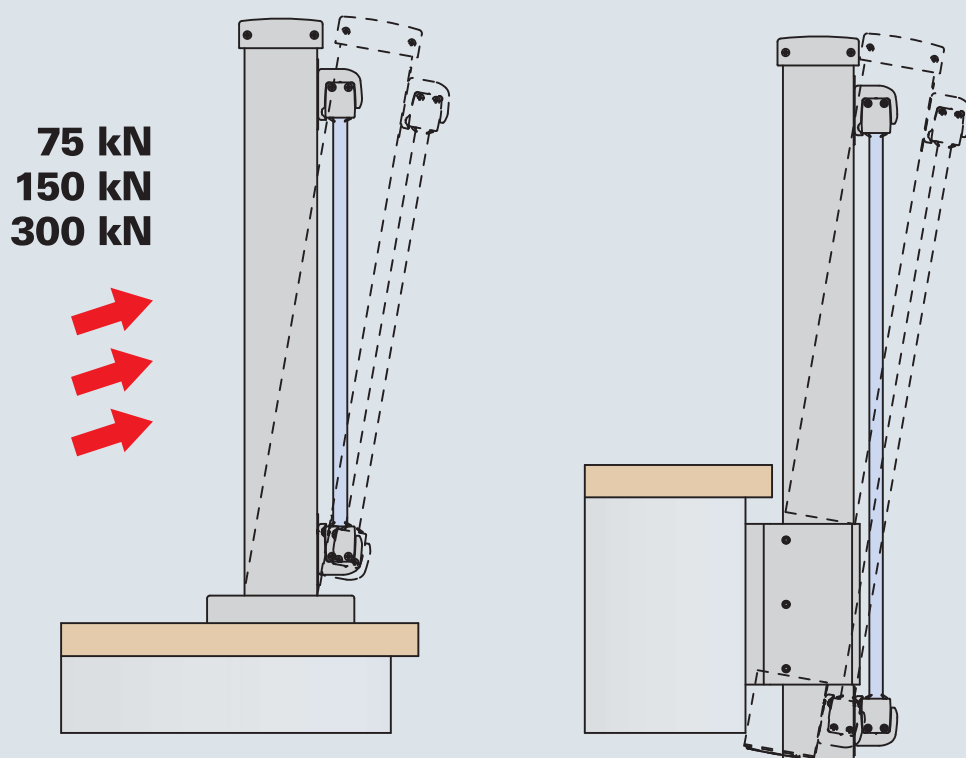

STRIPE

# FISSAGGIO STAFFA A PAVIMENTO

## FLOOR BRACKET INSTALLATION

### BEFESTIGUNG DER BODENHALTERUNG

**A**

Facilità di montaggio saetta al profilo palo (a cura del cliente) tramite viti.  
*Easy assembly (by the customer) of the reinforced steel bracket to the post profile by means of screws.*  
 Einfache bauseitige Montage der verstärkten Halterung am Pfostenprofil mittels Schrauben.

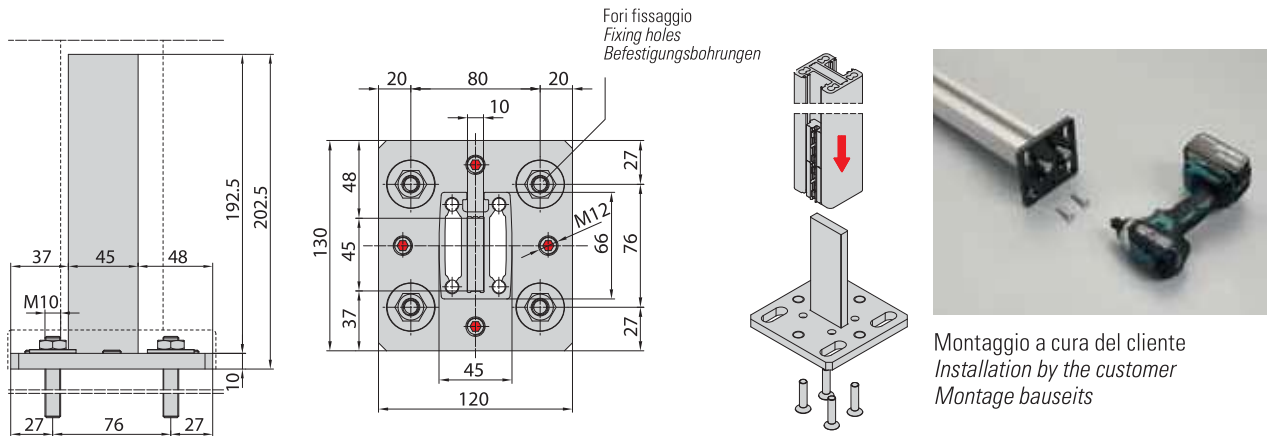

Montaggio a cura del cliente  
 Installation by the customer  
 Montage bauseits

**B**

Grazie alle asole e ai grani è possibile regolare la distanza e l'altezza dei pali.  
*Easy adjustment of the the distance and height of the posts thanks to the oval holes and the grub screws.*  
 Einfache Verstellung von Abstand und Höhe der Pfosten durch Langlöcher und Madenschrauben.

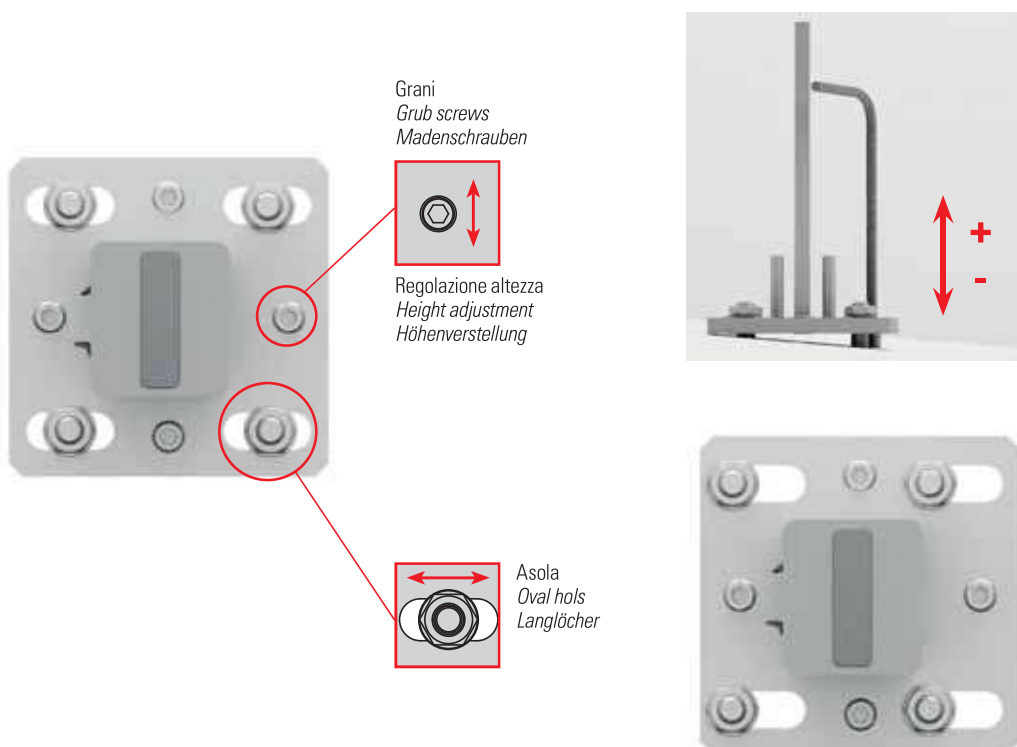

STRIPE

## STRIPE COLORI

*STRIPE COLORS*

*STRIPE OBERFLÄCHEN*

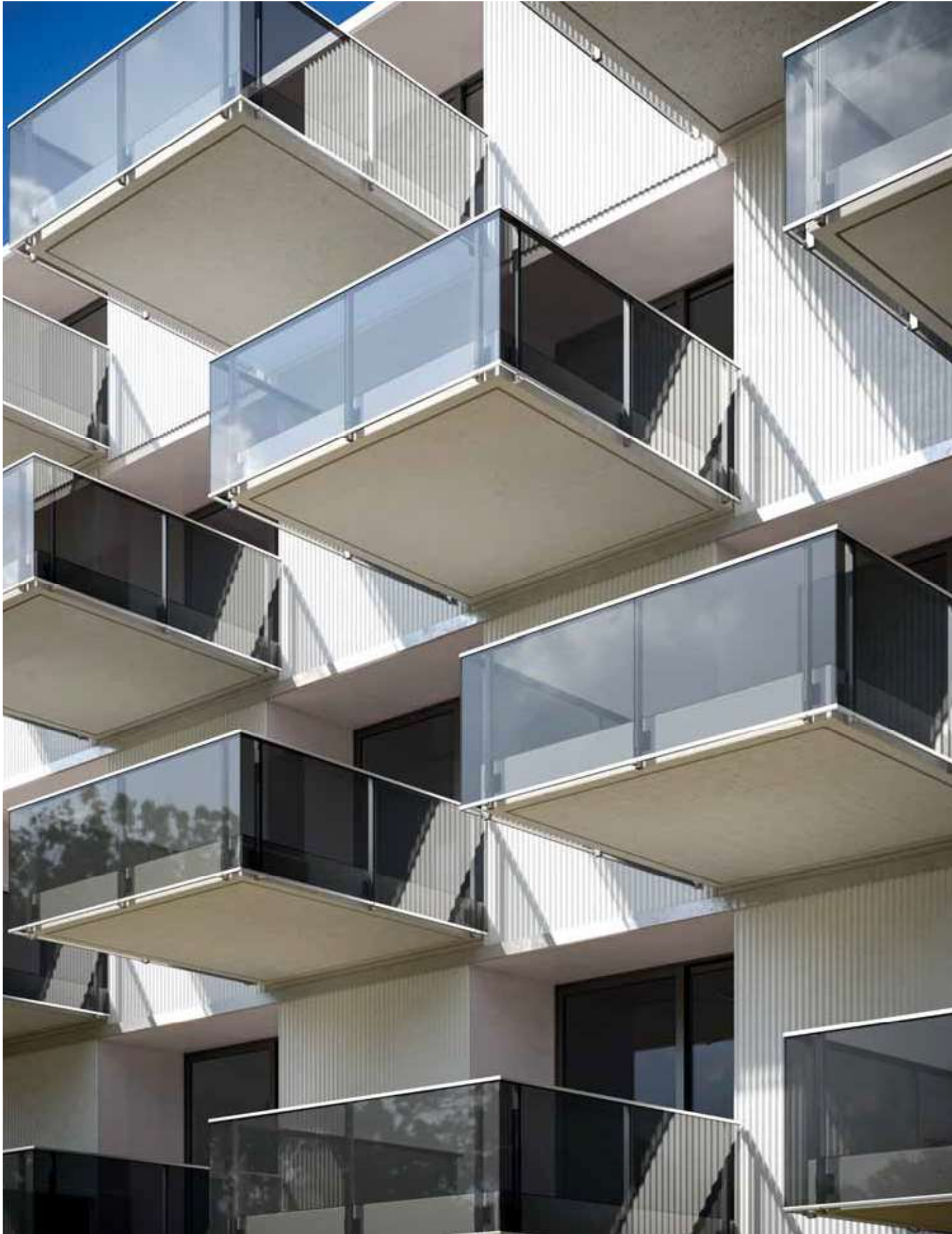

STRIPE



STRIPE



Colore standard consegna veloce: AN alluminio anodizzato argento  
*Standard color quick delivery: AN silver anodized aluminum*  
*Standard Oberfläche schnelle Lieferung: AN silberfarbiges eloxiertes Aluminium*



Altri colori a richiesta  
*Other colors on request*  
*Andere Oberflächen auf Anfrage*

## BP-350

VERSIONE CON CORRIMANO INDIPENDENTE, FISSAGGIO A PAVIMENTO  
VERSION WITH INDEPENDENT HANDRAIL, FLOOR INSTALLATION  
AUSFÜHRUNG MIT SEPARATEM HANDLAUF, BODENMONTAGE

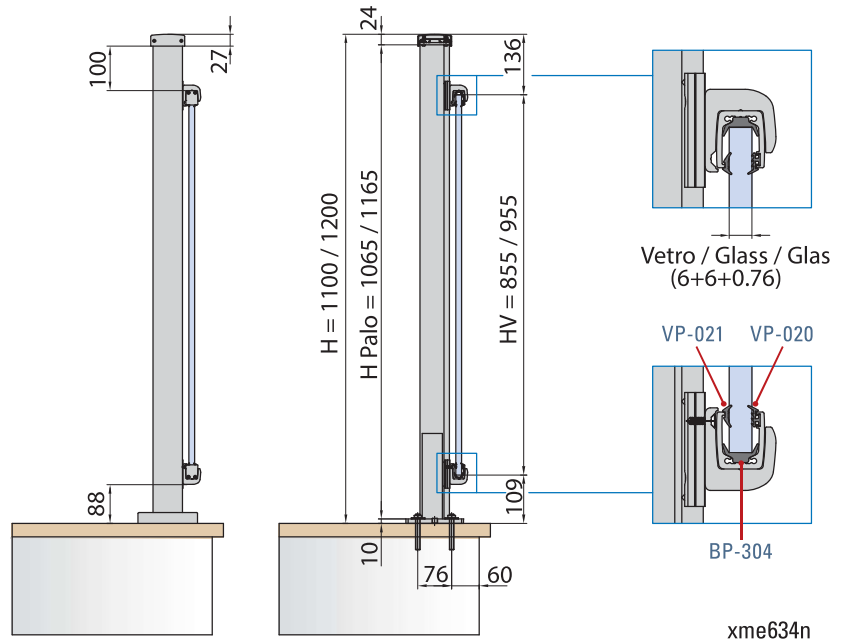

Set palo, fissaggio a pavimento. H=1100 mm/1200 mm.  
Per vetro 6+6+0.76. Profili corrimano e fermavetro non inclusi.  
Set floor installation post. H=1100 mm/1200 mm.  
For glass 6+6+0.76. Handrail and glass stop profiles not included.  
Set Pfosten, Bodenmontage. H=1100 mm/1200 mm.  
Für Glas 6+6+0.76. Handlauf und Glasleiste Profile nicht enthalten.

HV = H - 245  
H Palo = H - 34

HV = Altezza vetro / Glass height / Glashöhe  
H Palo = Altezza palo / Post height / Pfostenhöhe

### PAGINE TECNICHE / TECHNICAL PAGES / TECHNISCHE SEITEN ▶ 85

#### COMPONENTI / COMPONENTS / EINZELTEILE ▶ 86-87

STRIPE

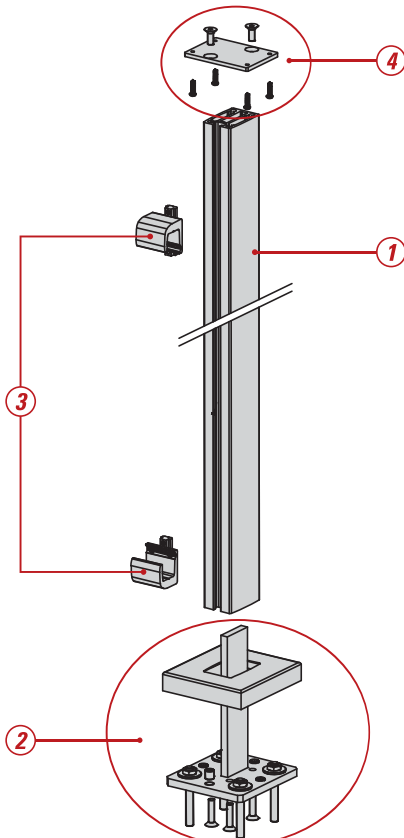

<p><b>1</b> BP-310 Profilo palo H = 1065 / 1165 mm Post profile H = 1065 / 1165 mm Pfostenprofil H = 1065 / 1165 mm</p>	<p>BP-304 Guarnizione appoggio vetro Support glass gasket Dichtung für Glas</p>
<p><b>2</b> BP-305 Staffa a pavimento regolabile compresa di coperture Adjustable floor bracket, cover plates included Verstellbare Bodenhalterung, inklusive Abdeckplatten</p>	<p>VP-020 Guarnizione 7 mm Gasket 7 mm Dichtung 7 mm</p>
<p><b>3</b> BP-306 Morsetto di sostegno per profilo fermavetro Connection clamp for glass stop profile Klemmverbinder für Glasleiste Profil 2 pcs</p>	<p>VP-021 Guarnizione 5 mm Gasket 5 mm Dichtung 5 mm</p>
<p><b>4</b> BP-307 Piastra di connessione palo/corrimano Post/handrail connection plate Verbindungsplatte Pfosten/Handlauf</p>	

#### NON INCLUSI NEL SET / NOT INCLUDED IN SET / NICHT IM SET ENTHALTEN

<p>BP-351 Profilo corrimano escluse guarnizioni Handrail profile, gaskets not included Handlauf Profil, Dichtungen nicht enthalten L = 3000 / L = 6000</p>
<p>BP-303 Profilo fermavetro, escluse guarnizioni Glass stop profile, gaskets not included Glasleiste Profil, Dichtungen nicht enthalten L = 3000 / L = 6000</p>

## SEZIONE TECNICA - TECHNICAL PAGES - TECHNISCHE SEITEN

**ESEMPI DI DISTANZA MASSIMA TRA I PALI**

EXAMPLES OF MAXIMUM DISTANCE BETWEEN POSTS

BEISPIELEN VON MAXIMALEM ABSTAND ZWISCHEN PFOSTEN



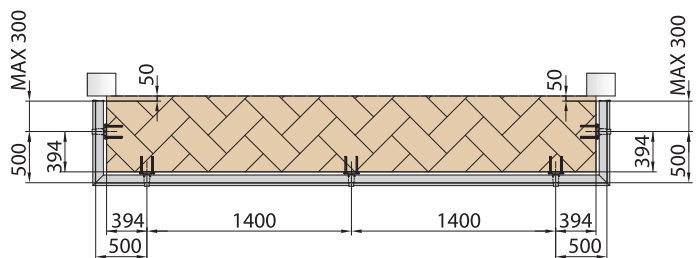
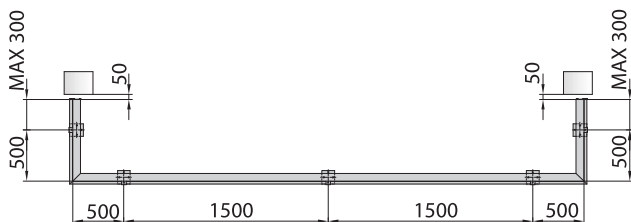
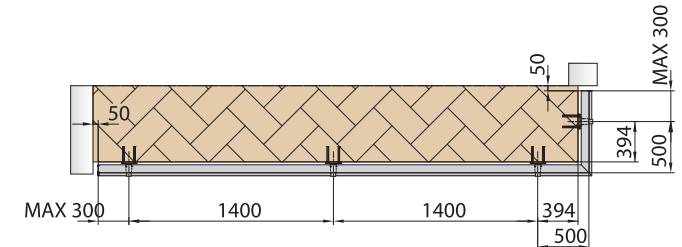
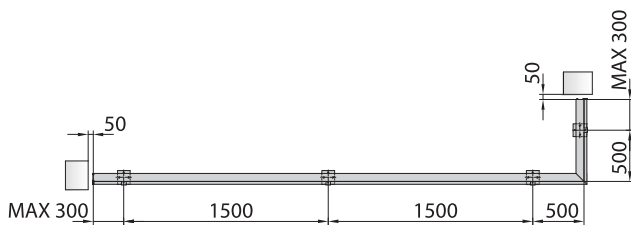
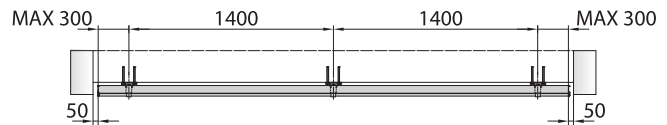
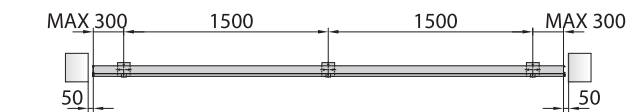
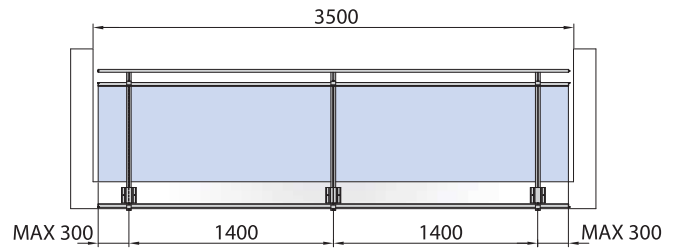
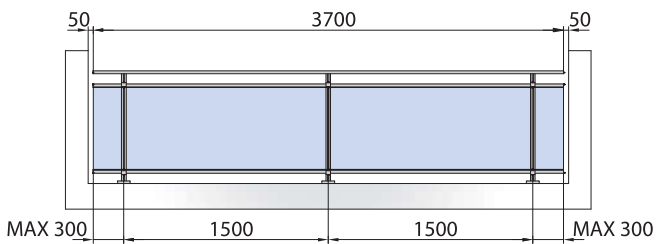

**FISSAGGIO A PAVIMENTO**  
 FLOOR INSTALLATION  
 BODENMONTAGE

**FISSAGGIO LATERALE**  
 SIDE INSTALLATION  
 SEITENMONTAGE

STRIPE

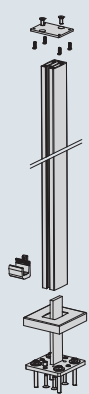
# COMPONENTI

## COMPONENTS EINZELTEILE

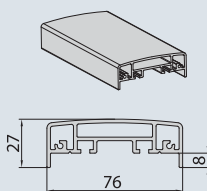
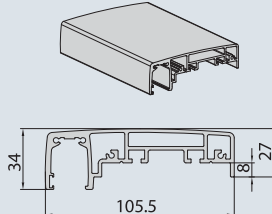
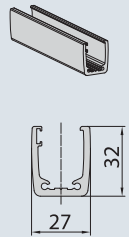
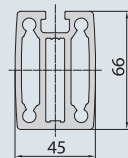
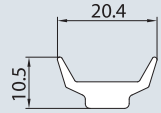
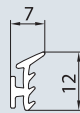
	<p><b>BP-300</b> Set palo compreso di staffa con saetta in acciaio, fissaggio a pavimento, morsetto vetro, tappi e guarnizioni. <i>Set post for floor installation, reinforced steel bracket, glas clamp, endcaps and gasket included.</i> <i>Set Pfosten, Bodenmontage, inklusive verstärkten Halterung, Glasklemme, Endkappe und Dichtungen.</i></p> <p>H = 1100 mm / 1200 mm</p> <p style="text-align: right;">xme634b</p>		<p><b>BP-320</b> Palo compreso di staffa con saetta in acciaio, fissaggio laterale, morsetto vetro, tappi e guarnizioni. <i>Set post for side installation, reinforced steel bracket, glas clamp endcaps and gaskets included.</i> <i>Set Pfosten, Seitenmontage, inklusive verstärkten Halterung, Glasklemme, Endkappen und Dichtungen.</i></p> <p>H = 1100 mm / 1200 mm</p> <p style="text-align: right;">xme634c</p>
	<p><b>BP-350</b> Palo compreso di staffa con saetta in acciaio, fissaggio a pavimento, morsetto vetro, tappi e guarnizioni. Versione per corrimano indipendente. <i>Set post for floor installation, reinforced steel bracket, glas clamp, endcaps and gasket included.</i> <i>Version for independent handrail.</i> <i>Set Pfosten, Bodenmontage, inklusive verstärkten Halterung, Glasklemme, Endkappe und Dichtungen.</i> <i>Ausführung für separaten Handlauf.</i></p> <p>H = 1100 mm / 1200 mm</p> <p style="text-align: right;">xme634a</p>		<p><b>BP-370</b> Palo compreso di staffa con saetta in acciaio, fissaggio laterale, morsetto vetro, tappi e guarnizioni. Versione per corrimano indipendente. <i>Set post for side installation, reinforced steel bracket, glas clamp endcaps and gaskets included.</i> <i>Version for independent handrail.</i> <i>Set Pfosten, Seitenmontage, inklusive verstärkten Halterung, Glasklemme, Endkappen und Dichtungen.</i> <i>Ausführung für separaten Handlauf.</i></p> <p>H = 1100 mm / 1200 mm</p> <p style="text-align: right;">xme634a</p>
<p style="writing-mode: vertical-rl; transform: rotate(180deg);"><b>STRIPE</b></p> 	<p><b>BP-351</b> Corrimano per pali BP-350 / BP-370. Versione per corrimano indipendente. <i>Handrail for posts BP-350 / BP-370.</i> <i>Version for independent handrail.</i> <i>Handlauf für Pfosten BP-350 / BP-370.</i> <i>Ausführung für separaten Handlauf.</i></p> <p>L = 3000 / 6000 mm</p> <p style="text-align: right;">xme634d</p>		<p><b>BP-301</b> Corrimano per pali BP-300 / BP-320. <i>Handrail for posts BP-300 / BP-320.</i> <i>Handlauf für Pfosten BP-300 / BP-320.</i></p> <p>L = 3000 / 6000</p> <p style="text-align: right;">xme634d</p>
	<p><b>BP-303</b> Profilo fermavetro, escluse guarnizioni. <i>Glas stop profile, gaskets not included.</i> <i>Glasleiste Profil, Dichtungen nicht enthalten</i></p> <p>L = 3000 / 6000 mm</p> <p style="text-align: right;">xme634d</p>		<p><b>BP-310</b> Profilo palo. <i>Post profile.</i> <i>Pfostenprofil.</i></p> <p>H = 1065 / 1165 / 1350 / 1450 mm</p> <p style="text-align: right;">xme634d</p>
	<p><b>BP-304</b> Guarnizione appoggio vetro. <i>Support glass gasket.</i> <i>Dichtung für Glas.</i></p> <p style="text-align: right;">xme634e</p>		<p><b>VP-020</b> Guarnizione 7 mm. <i>Gasket 7 mm.</i> <i>Dichtung 7 mm.</i></p> <p style="text-align: right;">xme634e</p>

# COMPONENTI

## COMPONENTS

### EINZELTEILE

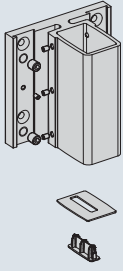
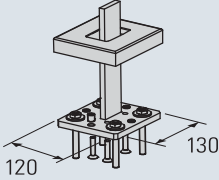
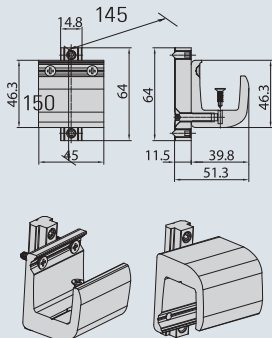
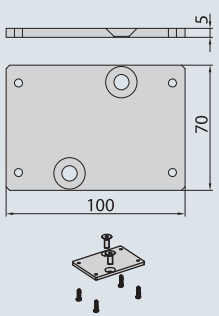
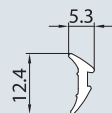
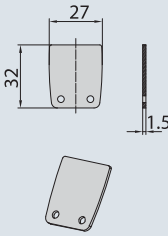
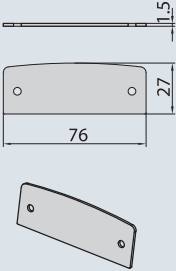
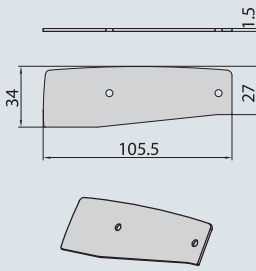
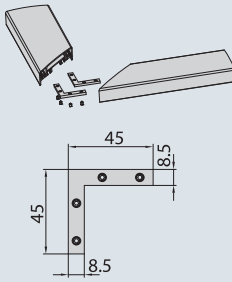
	<p><b>BP-325</b> Staffa laterale regolabile con coperture. <i>Adjustable side bracket, cover plates included.</i> Verstellbare seitliche Halterung, inkl. Abdeckplatten.</p>		<p><b>BP-305</b> Staffa a pavimento regolabile compresa di coperture. <i>Adjustable floor bracket, cover plates included.</i> Verstellbare Bodenhalterung, inklusive Abdeckplatten.</p>
	<p><b>BP-306</b> Morsetto di sostegno per profilo fermavetro. <i>Connection clamp for glass stop profile.</i> Klemmverbinder für Glasleiste Profil.</p>		<p><b>BP-307</b> Piastra di connessione palo/corrimano. <i>Post/handrail connection plate.</i> Verbindungsplatte Pfosten/Handlauf.</p>
	<p><b>VP-021</b> Guarnizione 5 mm. <i>Gasket 5 mm.</i> Dichtung 5 mm.</p>		<p><b>BP-311</b> Tappo per corrimano BP-303. <i>Endcap for handrail BP-303.</i> Endkappe für Handlauf BP-303.</p>
	<p><b>BP-309</b> Tappo per corrimano BP-351. <i>Endcap for handrail BP-351.</i> Endkappe für Handlauf BP-351.</p>		<p><b>BP-308</b> Tappo per corrimano BP-301. <i>Endcap for handrail BP-301.</i> Endkappe für Handlauf BP-301.</p>
	<p><b>P-F44</b> Kit di due staffe angolari. <i>Set corner installation brackets.</i> Set Eckbefestigungswinkel.</p>		



STRIPE