

BALCONE ALLA FRANCESE

JULIET BALCONY
FRANZÖSISCHER BALKON

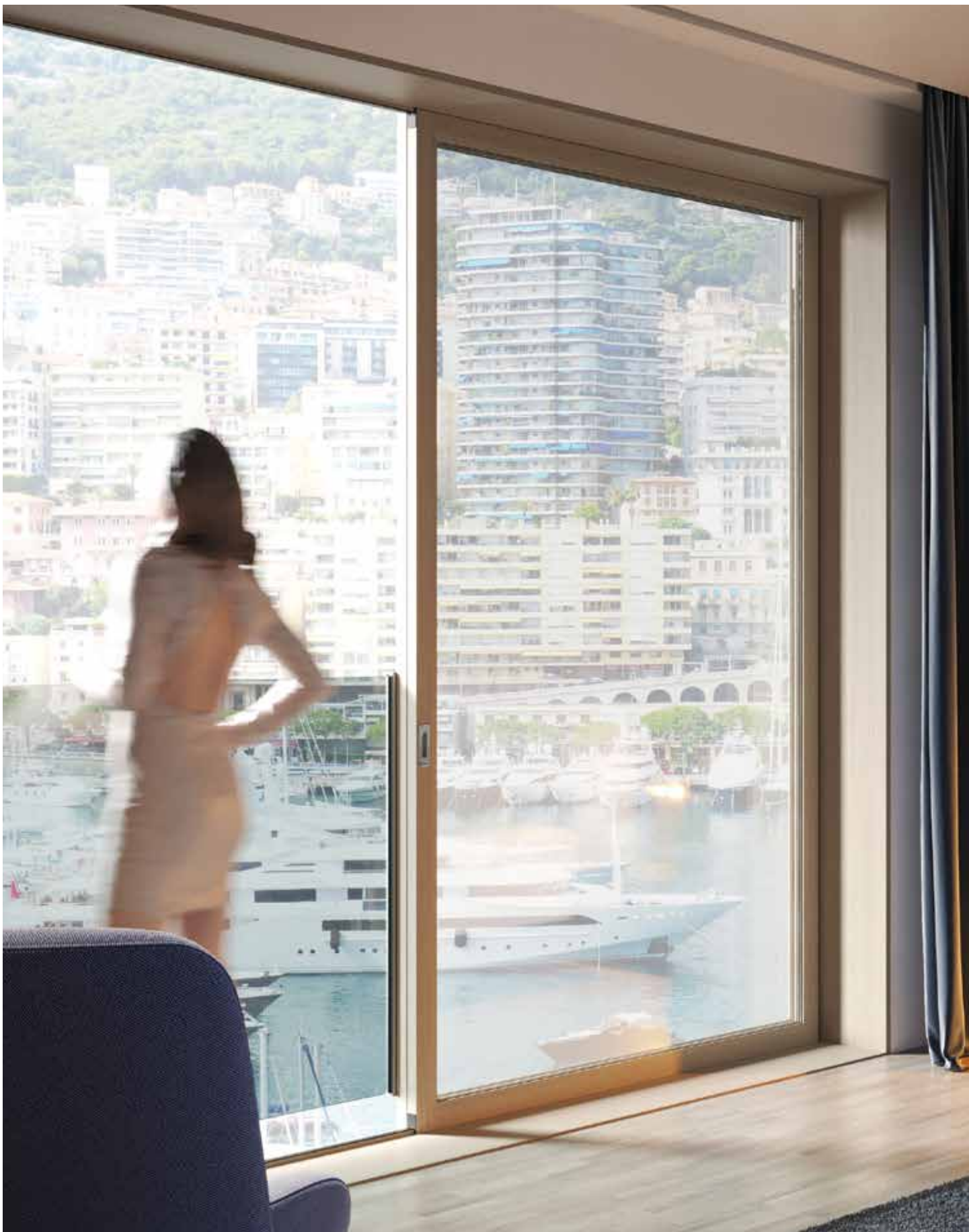

BF-100

BALCONE ALLA FRANCESE

JULIET BALCONY

FRANZÖSISCHER BALKON

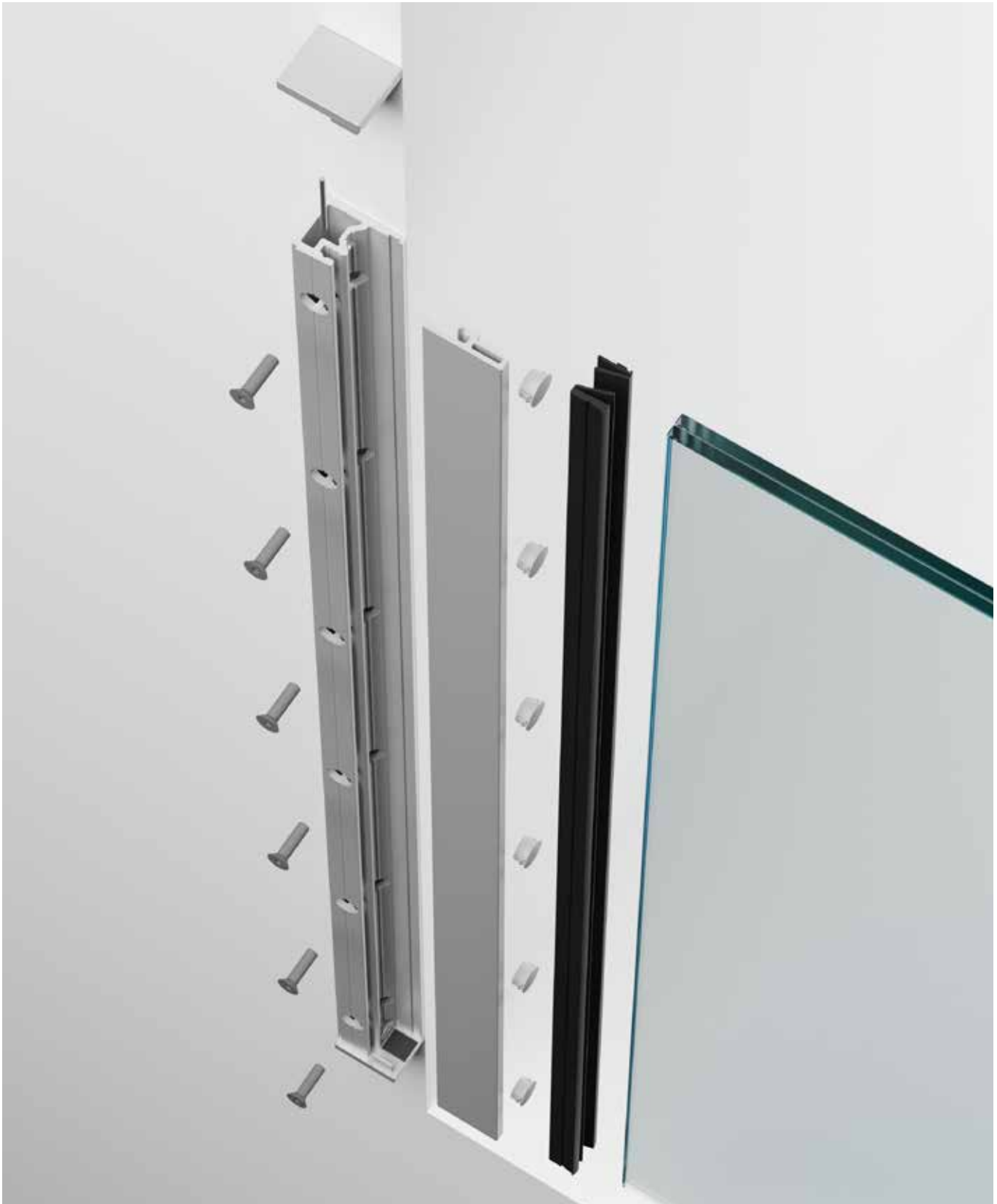

CERTIFICAZIONI

CERTIFICATIONS
PRÜFTBERICHTE



UNIVERSITÀ DEGLI STUDI DI BRESCIA
DICATAM DIPARTIMENTO DI INGEGNERIA CIVILE, ARCHITETTURA,
TERRITORIO, AMBIENTE E DI MATEMATICA
LABORATORIO PROVE MATERIALI «PIETRO PISA»

SET	Vetro mm Glass mm Glas mm	L	H Vetro H Glass H Glas	Testato spinta Test side force Getestete Seitenkraft	Classe Class it Klasse	UNI11678:2017
BF-100	8+8+1,52 pvb	1500 mm	1100 mm	150 Kg	1	1 kN/m = 100kg/m
	8+8+1,52 pvb	1500 mm	1100 mm	300 Kg	2	2 kN/m = 200kg/m
	10+10+1,52 pvb	1500 mm 1500 mm 1500 mm	1100 mm 1100 mm 1100 mm	150 Kg 300 Kg 450 Kg	1 2 3	1 kN/m = 100kg/m 2 kN/m = 200kg/m 3 kN/m = 300kg/m

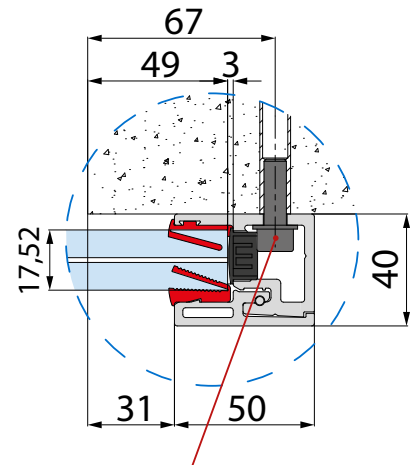
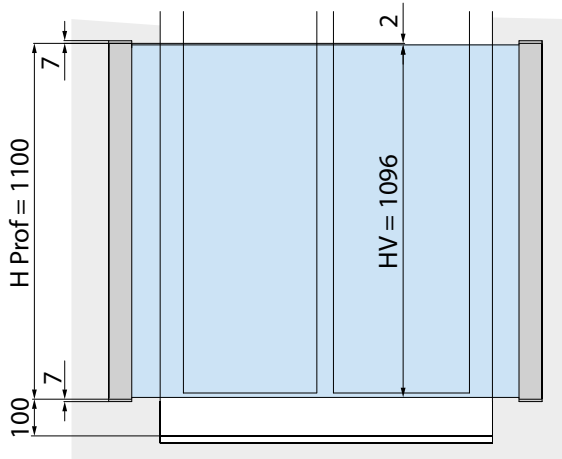

Testato con vite M8 testa cilindrica
Tested with M8 cylindrical head screw
Geprüft mit Zylinderkopfschraube M8





BALCONE ALLA FRANCESE

BF-100



Set montanti per fissaggio in nicchia o esterno muro, completo di guarnizioni e tappi.
Per vetro 8+8+1.52 / 10+10+1.52. H = da 350 a 1100 mm.
*2-Part complete set, niche or side installation, gaskets and endcaps included.
For glass 8+8+1.52 / 10+10+1.52. H = from 350 to 1100 mm.*
*2-tlg. Komplett-set, Nischen- oder Seitenmontage, inklusive Dichtungen und Endkappen.
Für Glas 8+8+1.52 / 10+10+1.52. H = von 350 bis 1100 mm.*



SET	Vetro mm Glass mm Glas mm	L	H Vetro H Glass H Glas	Testato spinta Test side force Getestete Seitenkraft	Classe Class ITA Klasse ITA	UNI11678:2017
BF-100	8+8+1,52 pvb	1500 mm	1100 mm	150 Kg	1	1 kN/m = 100kg/m
	8+8+1,52 pvb	1500 mm	1100 mm	300 Kg	2	2 kN/m = 200kg/m
	10+10+1,52 pvb	1500 mm	1100 mm	150 Kg	1	1 kN/m = 100kg/m
		1500 mm	1100 mm	300 Kg	2	2 kN/m = 200kg/m
		1500 mm	1100 mm	450 Kg	3	3 kN/m = 300kg/m

MONTAGGIO IN NICCHIA

NICHE INSTALLATION
 NISCHENMONTAGE

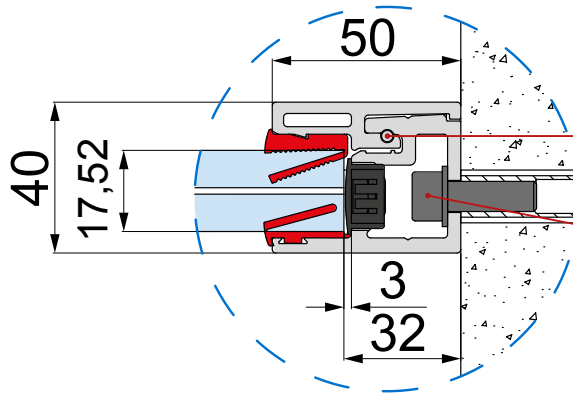

Spina di sicurezza inclusa
 Safety pin included
 Sicherheitsstifte enthalten
 Ø 3 x L. 500 mm

Testato con vite M8 testa cilindrica
 Tested with M8 cylindrical head screw
 Geprüft mit Zylinderkopfschraube M8

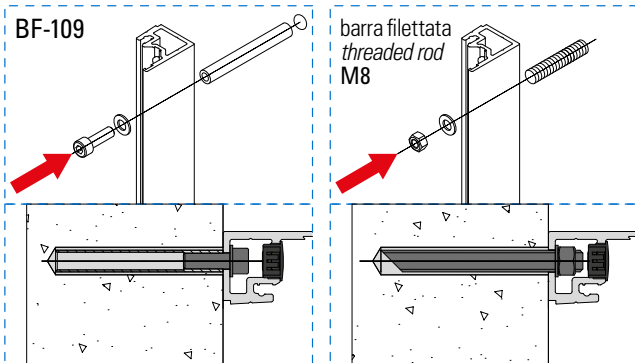
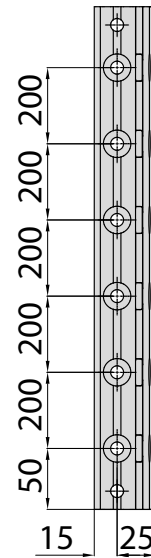
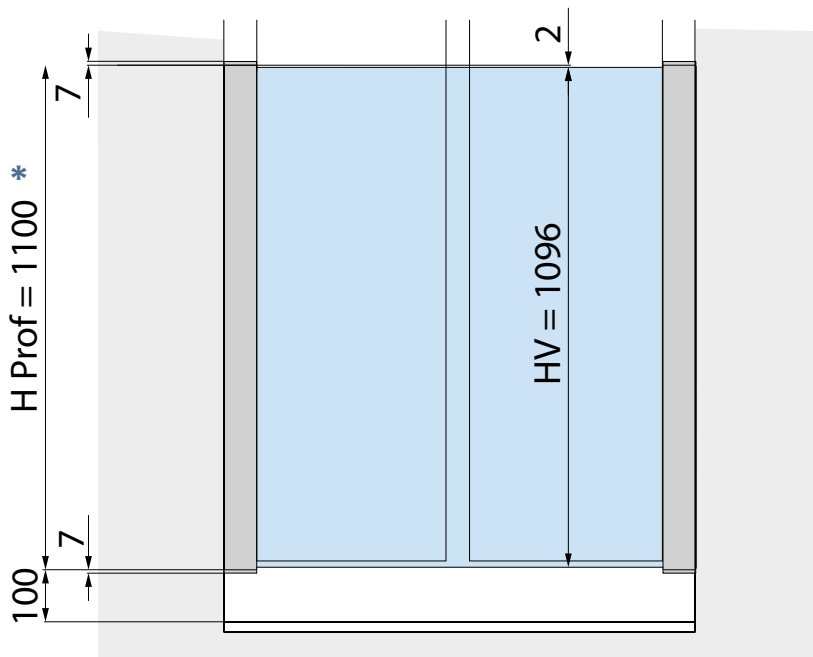
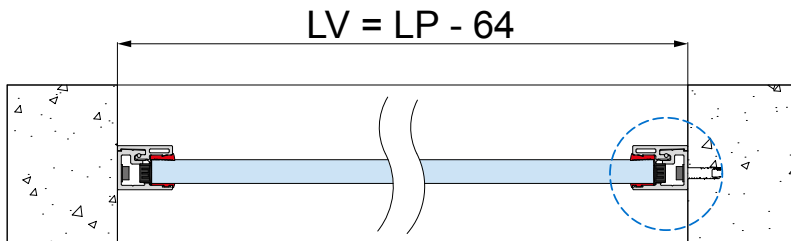

BF-109 (optional)

Kit ancoraggio profilo a parete/muro.
 Confezione da 6 pezzi
 Profile wall fixing kit. Package unit 6 pcs
 Wandbefestigungsset für Profile.
 VE 6 Stk

* Per fuori misura vedi pag. 104
 For other sizes see page 104
 Für weitere Maßen siehe Seite 104



MONTAGGIO PARETE

WALL INSTALLATION
WANDMONTAGE

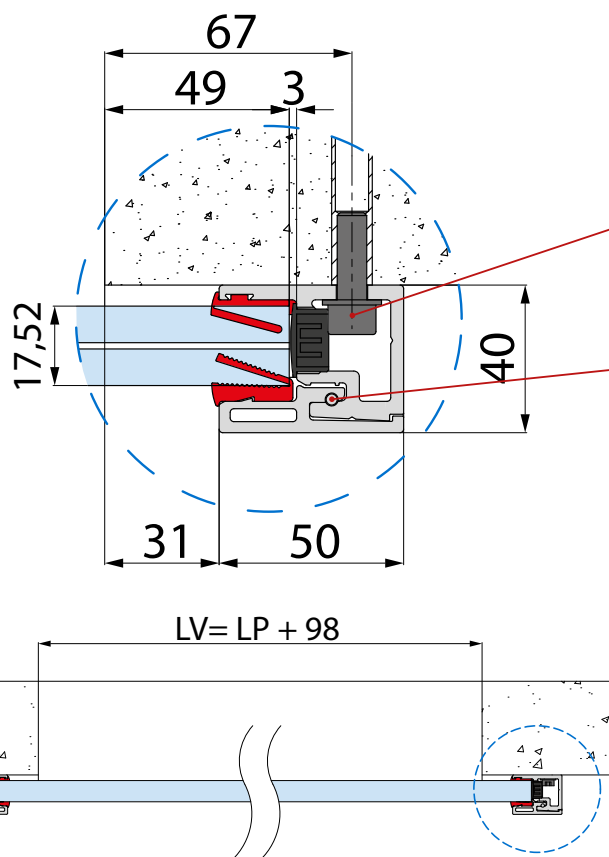

Testato con vite M8 testa cilindrica
Tested with M8 cylindrical head screw
Geprüft mit Zylinderkopfschraube M8

Spina di sicurezza inclusa
Safety pin included
Sicherheitsstifte enthalten
Ø 3 x L. 500 mm

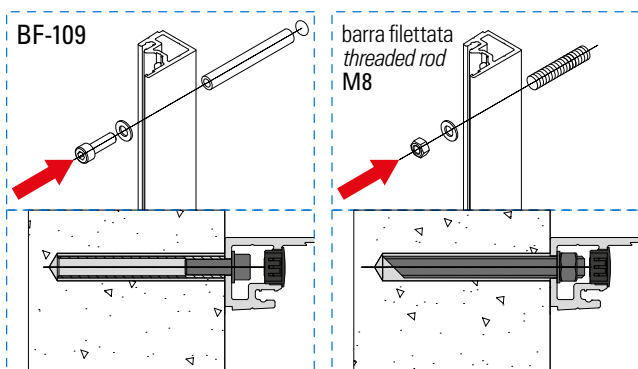
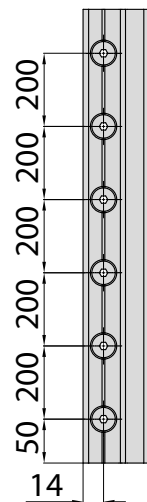
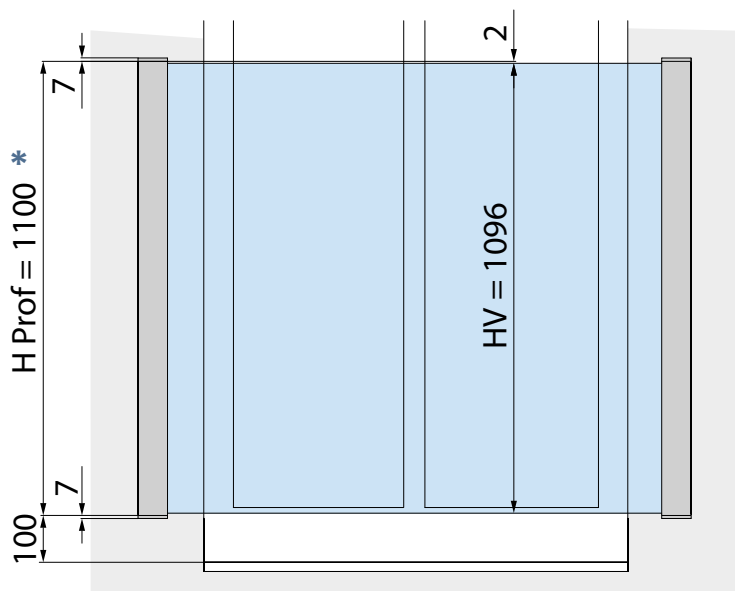

BF-109 (optional)
Kit ancoraggio profilo a parete/muro.
Confezione da 6 pezzi
Profile wall fixing kit. Package unit 6 pcs
Wandbefestigungsset für Profile.
VE 6 Stk

* Per fuori misura vedi pag. 104
For other sizes see page 104
Für weitere Maßen siehe Seite 104

MONTAGGIO SU STIPITE

FRAME INSTALLATION
 ZARGENMONTAGE

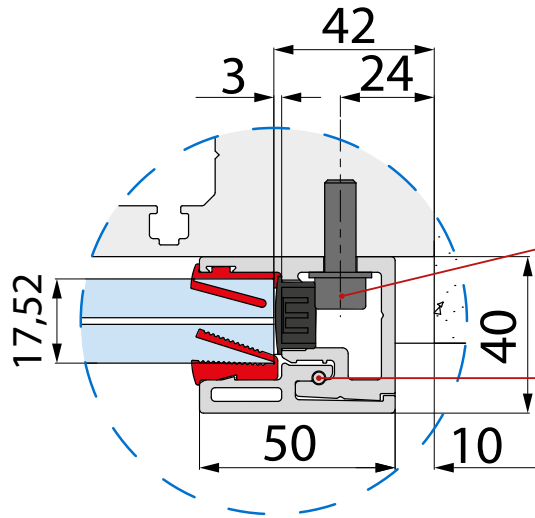

Testato con vite M8 testa cilindrica
 Tested with M8 cylindrical head screw
 Geprüft mit Zylinderkopfschraube M8

Spina di sicurezza inclusa
 Safety pin included
 Sicherheitsstifte enthalten
 Ø 3 x L. 500 mm

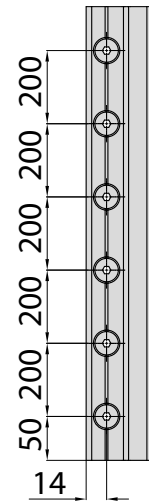
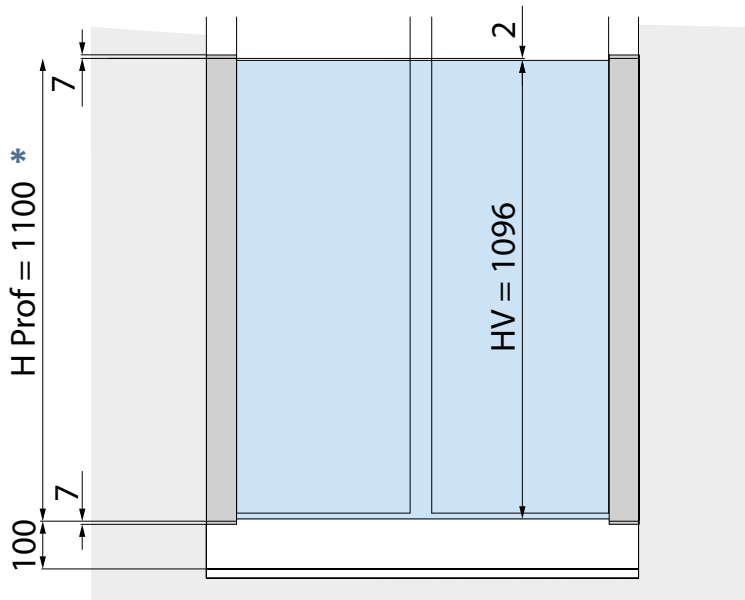
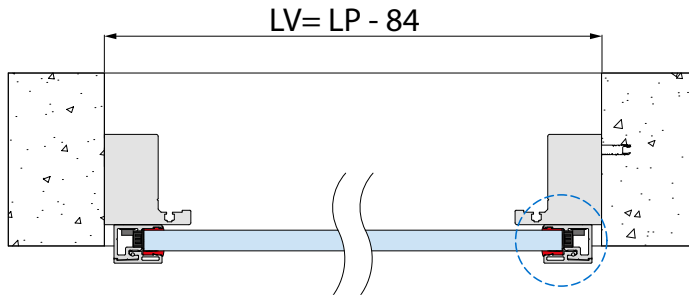

* Per fuori misura vedi pag. 104
 For other sizes see page 104
 Für weitere Maßen siehe Seite 104



ALCUNE TIPOLOGIE DI APPLICAZIONE

SOME APPLICATIONS EXAMPLES

EINIGE INSTALLATIONSMÖGLICHKEITEN





BALCONE ALLA FRANCESE

MONTAGGIO IN NICCHIA SU PARETE

NICHE INSTALLATION ON THE INSIDE OF THE WALL
NISCHENMONTAGE AN DER INNENSEITE DER WAND

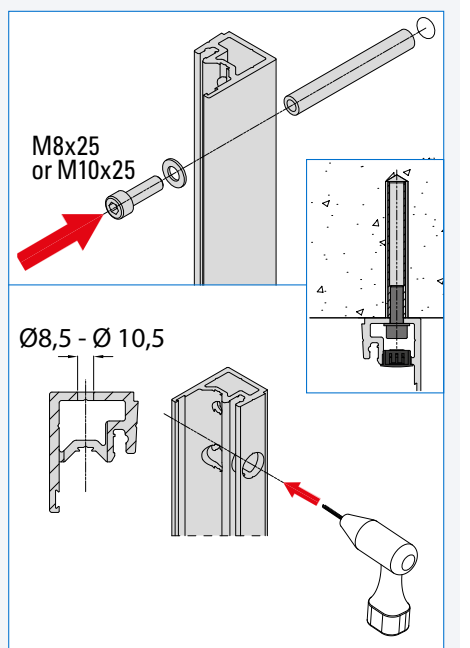
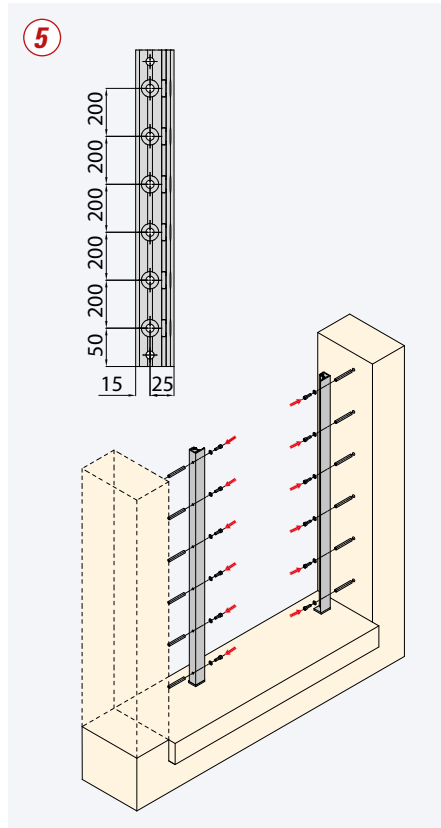
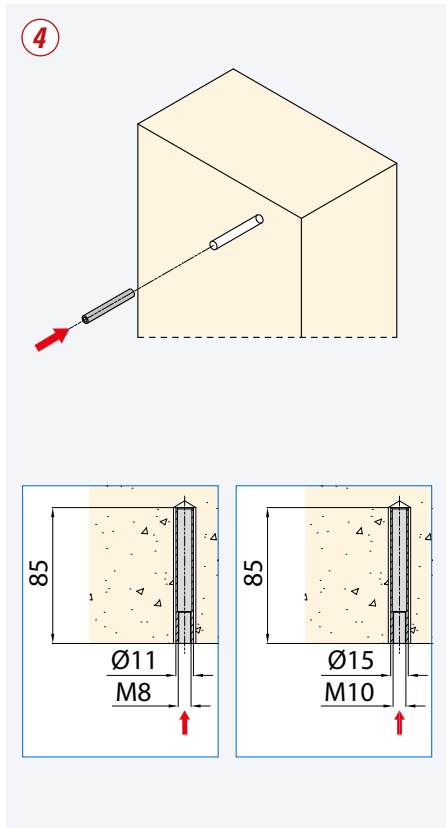
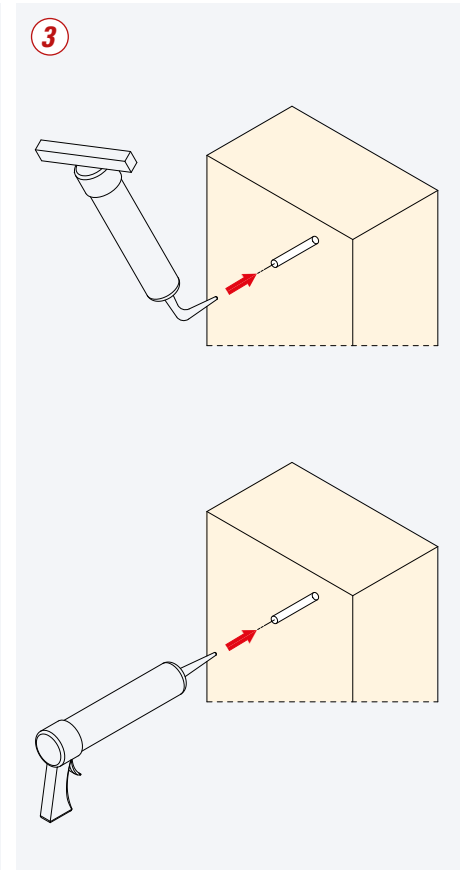
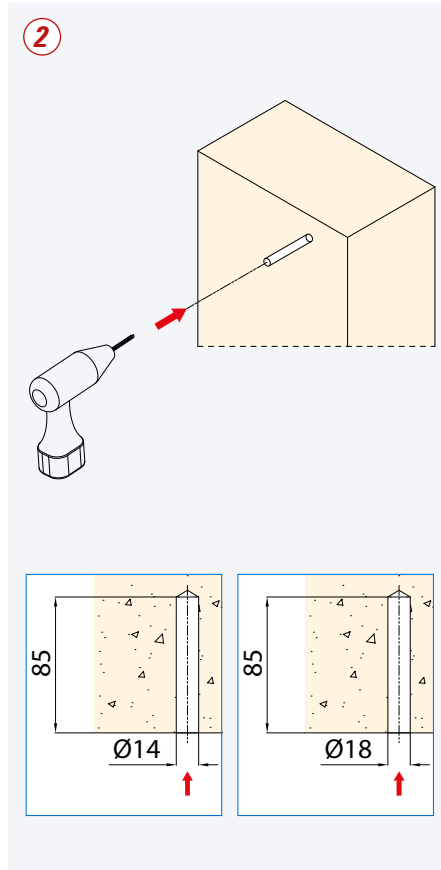
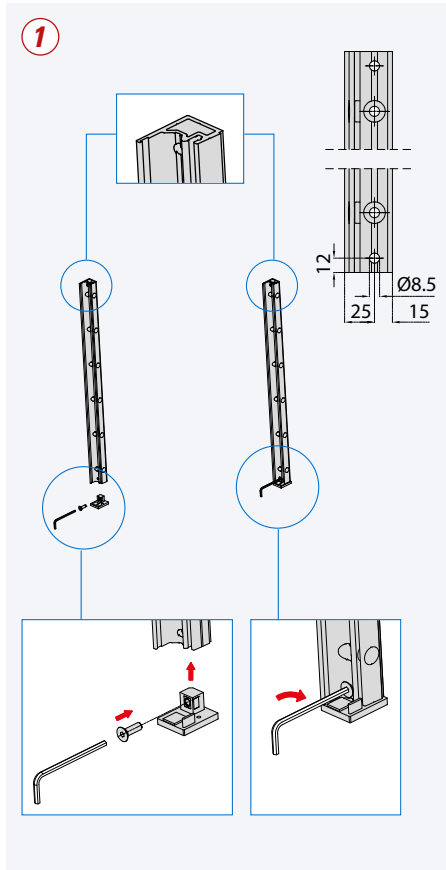
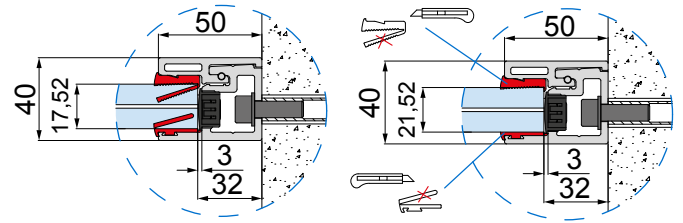

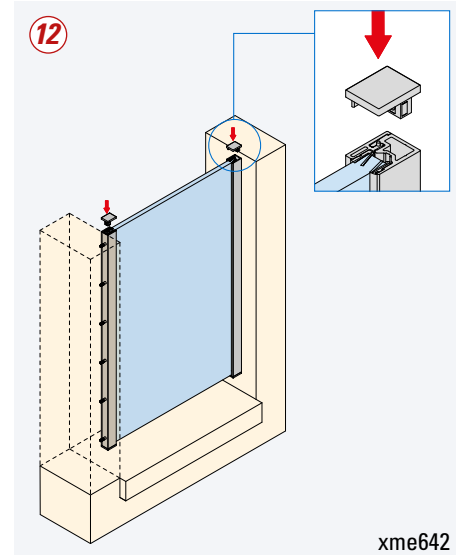
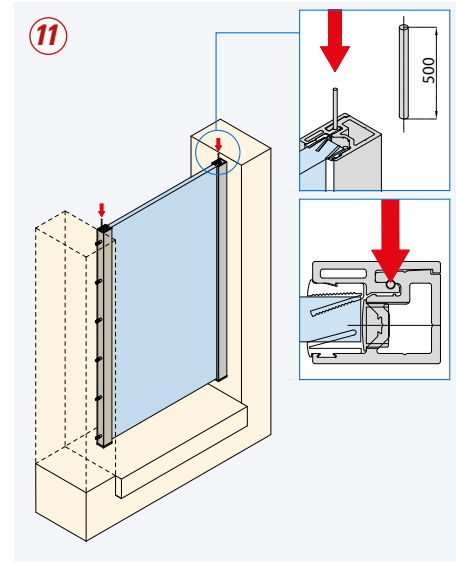
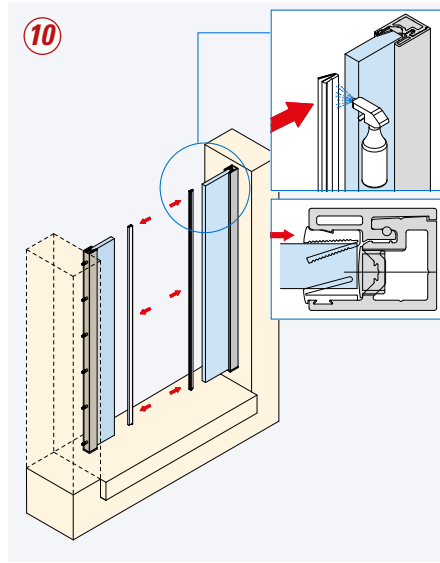
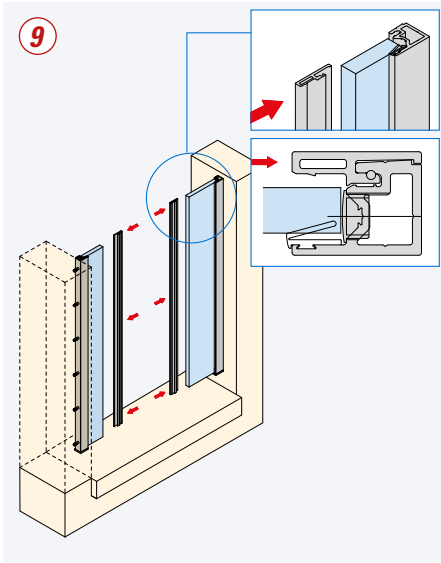
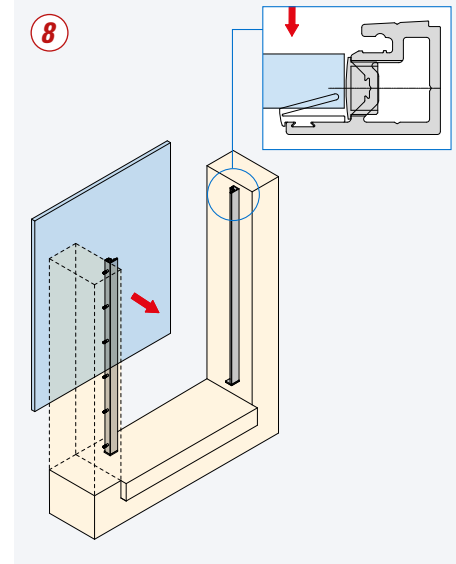
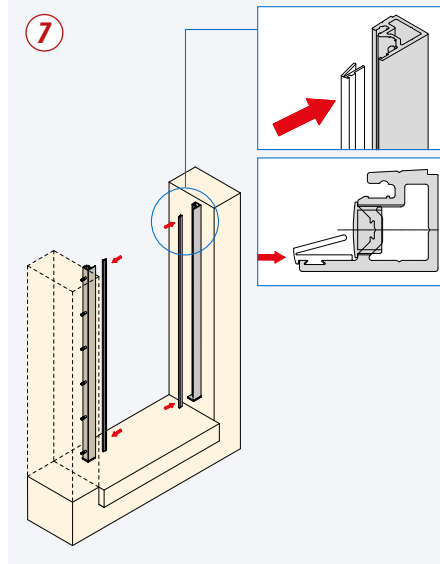
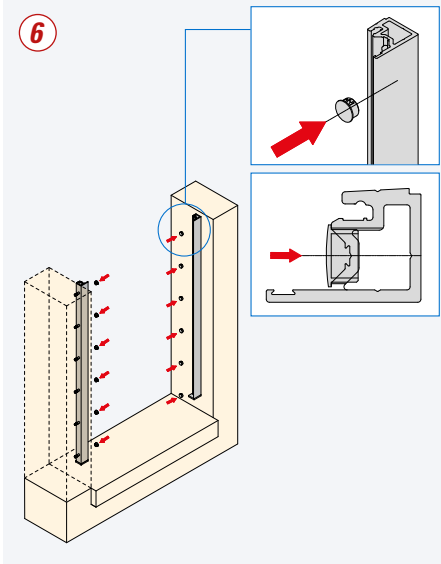

5

- Foro su profilo a cura del cliente, diametro variabile in base all'ancoraggio.
Min Ø 8.5 mm - Max Ø 10.5 mm.
Importante:
forare al centro rispetto a pre-foro da Ø 18.5 mm. Articolo testato con vite M8 testa cilindrica.
- Drilling on the profile by the customer, variable diameter depending on the anchoring.
Min Ø 8.5 mm - Max Ø 10.5 mm.
Important note:
drill in the center of the 18.5 mm pilot hole. Article tested with M8 cylindrical head screw.
- Bohrung am Profil bauseits, Durchmesser variabel je nach Verankerung.
Min Ø 8.5 mm - Max Ø 10.5 mm.
Wichtiger Hinweis:
in der Mitte der 18,5 mm Vorbohrung bohren. Artikel geprüft mit Zylinderkopfschraube M8.

xme642

MONTAGGIO ESTERNO

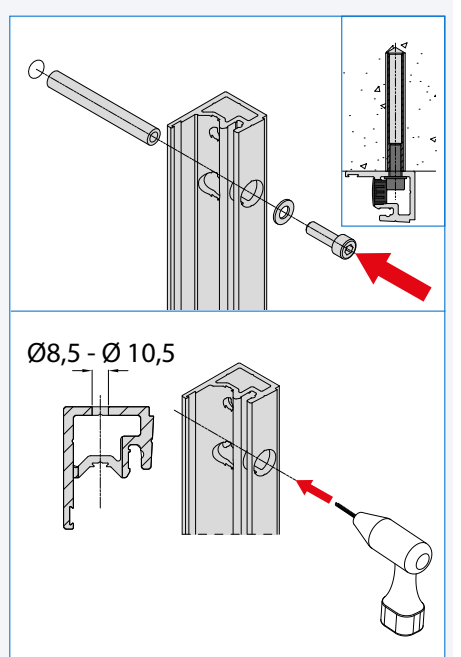
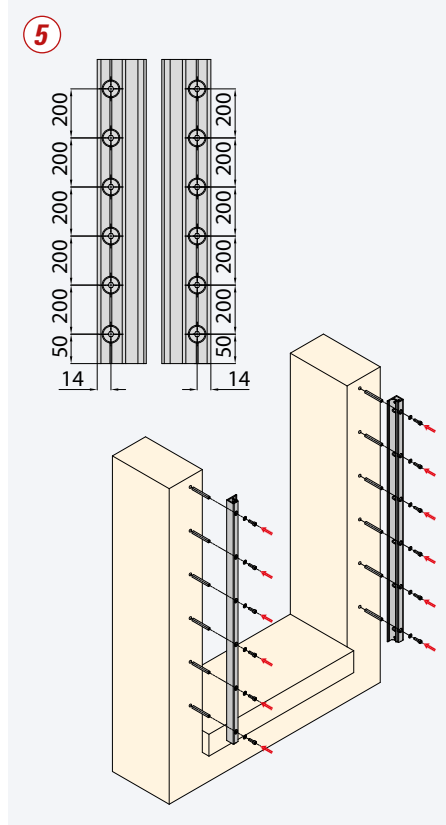
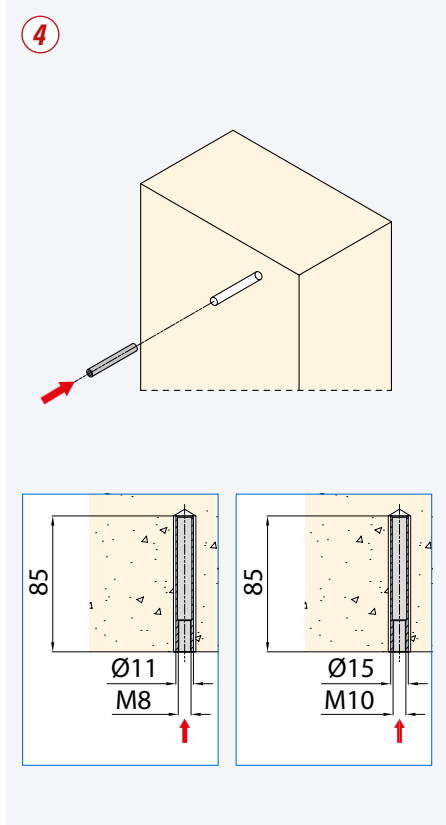
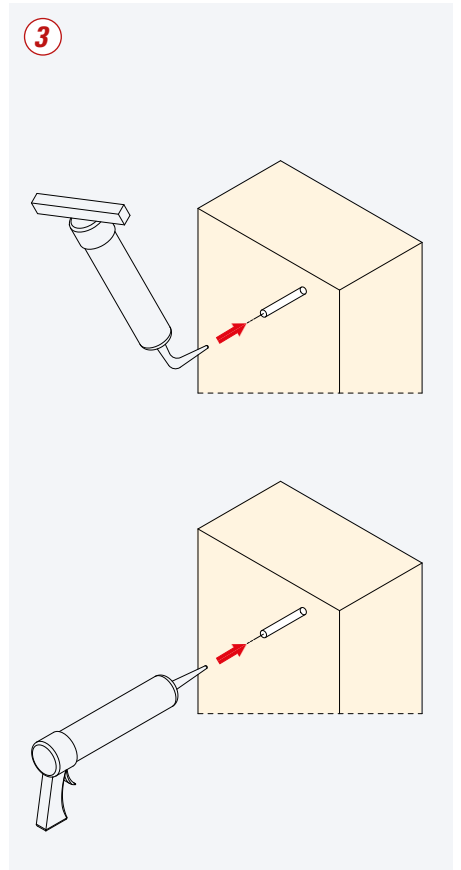
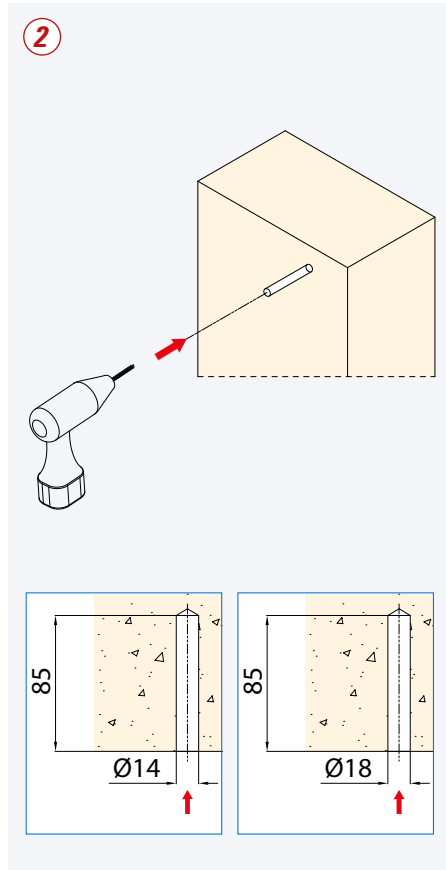
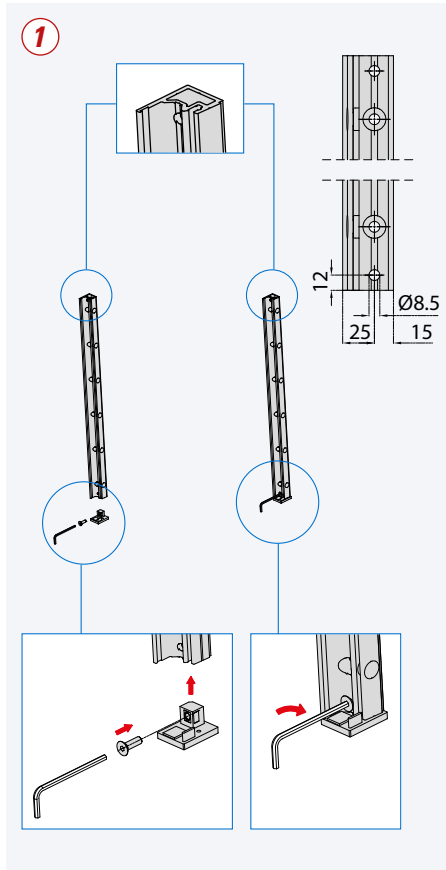
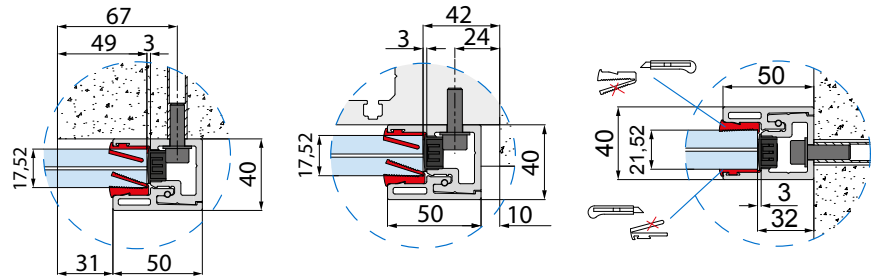
WALL INSTALLATION
WANDMONTAGE

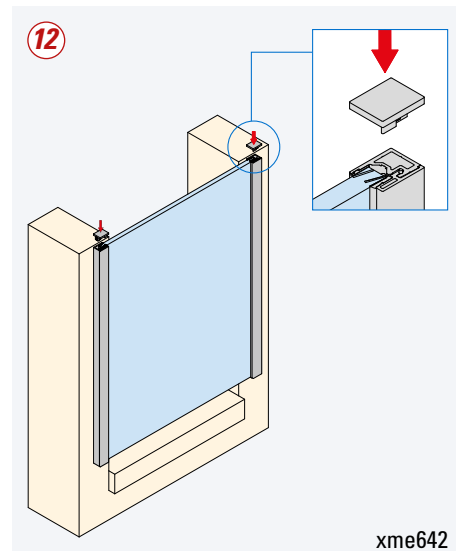
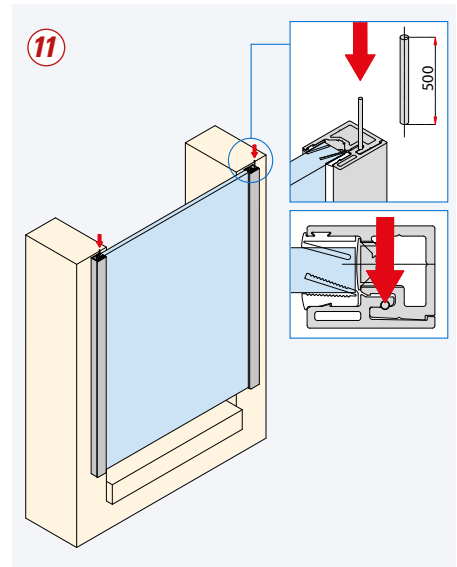
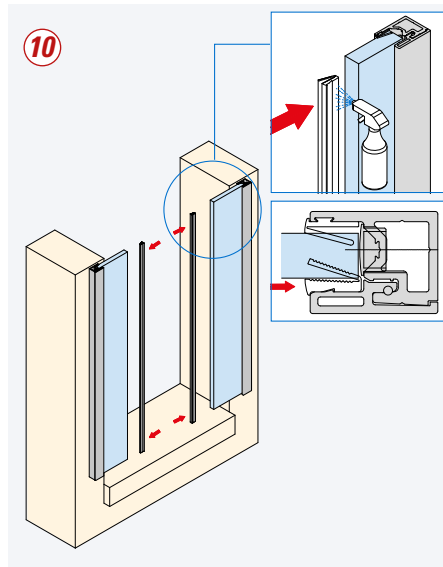
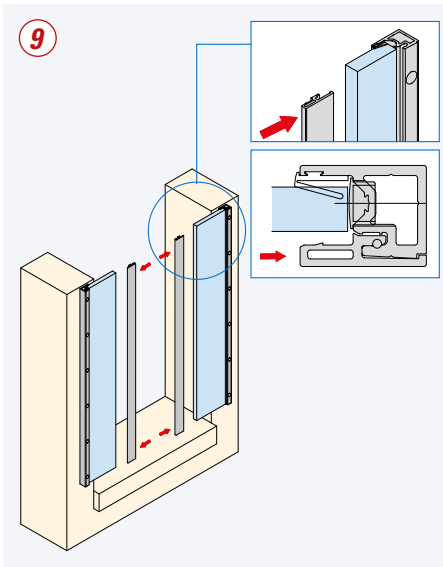
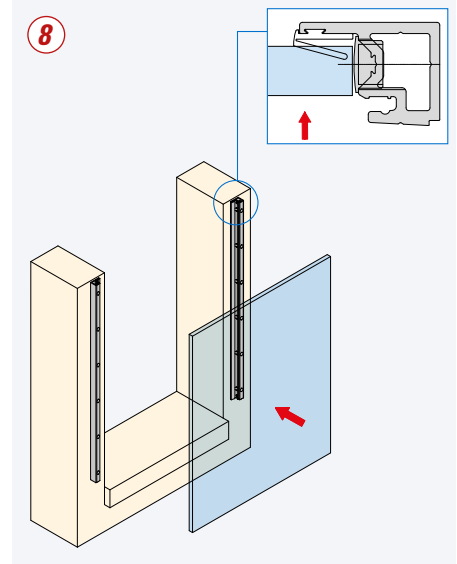
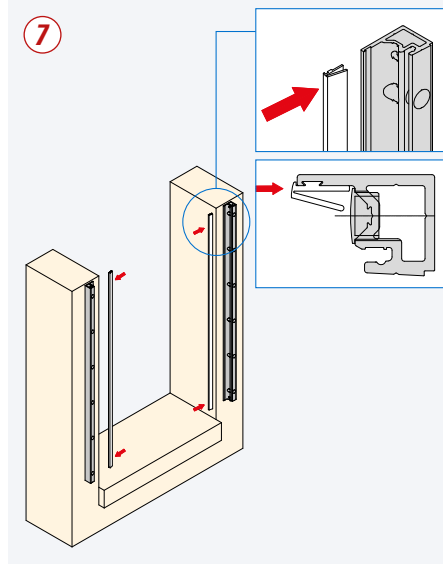
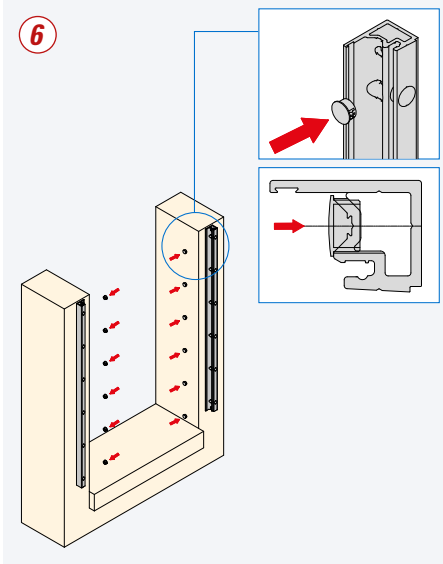

BALCONE ALLA FRANCESE

5

- Foro su profilo a cura del cliente, diametro variabile in base all'ancoraggio.
Min \varnothing 8.5 mm - Max \varnothing 10.5 mm.
Importante:
forare al centro rispetto a pre-foro da \varnothing 18.5 mm. Articolo testato con vite M8 testa cilindrica.
- Drilling on the profile by the customer, variable diameter depending on the anchoring.
Min \varnothing 8.5 mm - Max \varnothing 10.5 mm.
Important note:
drill in the center of the 18.5 mm pilot hole. Article tested with M8 cylindrical head screw.
- Bohrung am Profil bauseits, Durchmesser variabel je nach Verankerung.
Min \varnothing 8.5 mm - Max \varnothing 10.5 mm.
Wichtiger Hinweis:
in der Mitte der 18,5 mm Vorbohrung bohren. Artikel geprüft mit Zylinderkopfschraube M8.

xme642





BALCONE ALLA FRANCESE