



SCORREVOLI



BX-6050 PURA

VEDRAI L'USUALE CON OCCHI DIVERSI

Con Etere ci siamo accorti che per noi innovare è consuetudine. Volevamo semplificare un prodotto classico per renderlo il più possibile minimale, bello ed accattivante, ed alla fine abbiamo fatto "scompare tutto".

PER IL SUO DESIGN E PER L'INNOVAZIONE CHE LA CONTRADDISTINGUE ETEREA SI CANDIDA AD ESSERE LA MIGLIORE SUL MERCATO.

YOU WILL SEE THE USUAL WITH DIFFERENT EYES

With Etere we realised that it is customary for us to innovate. We set out to simplify a classic product to make it as minimal, beautiful and as alluring as possible, and ultimately we made "everything disappear". Due to its design and the innovation that distinguishes it, Etere boasts it is the best on the market.

SIE WERDEN DAS NORMALE MIT ANDEREN AUGEN BETRACHTEN

Mit Etere haben wir bemerkt, dass Innovation für uns üblich ist. Wir wollten ein klassisches Produkt vereinfachen, um es möglichst minimal zu gestalten, schön und attraktiv, und schließlich haben wir „alles verschwinden lassen“. Aufgrund des herausragenden Designs und der Innovation konkurriert Etere, um die Beste auf dem Markt zu werden.



**BOX DOCCIA
MODELLO TRADIZIONALE**

TRADITIONAL SHOWER ENCLOSURE MODEL
TRADITIONELLES DUSCHKABINEMODELL

**INVISIBILE IN
PURA
BX-6050**

INVISIBLE IN PURA BX-6050
UNSICHTBAR PURA BX-6050



SCORREVOLI

NEW

PLUS

- DESIGN "TECNICO" CON RUOTE A VISTA
- NESSUNO STOPPER A VISTA
- SISTEMA ANTISOLLEVAMENTO DI SICUREZZA INVISIBILE

- "Technical" design, visible wheels
- No visible stopper
- Invisible safety anti-lift system

- "Technisches" Design mit sichtbaren Räder
- Kein sichtbarer Stopper
- Unsichtbare Sicherung gegen das Hochschieben

BX-6050 PURA

- Profilo completamente libero e semplificazione della pulizia, quindi eliminazione totale di depositi e residui dovuti al normale utilizzo. Costruita in alluminio è disponibile nelle finiture cromo lucido e effetto inox.
- A completely free profile also means simplification of cleaning, therefore complete elimination of deposits and residues due to normal use. Made of aluminium, it is available in polished chrome and inox effect.
- Ein vollständig freies Profil bedeutet auch vereinfachte Reinigung, daher werden Ablagerungen und Rückstände durch normalen Gebrauch komplett beseitigt. Hergestellt aus Aluminium und ist mit Oberflächen in Chrom glänzend und Edelstahl ähnlich.



SCORREVOLI





SET 1

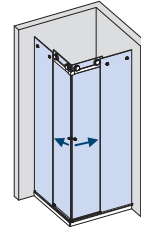

SET 2

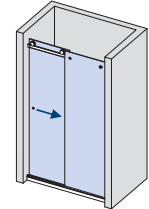

SET 3

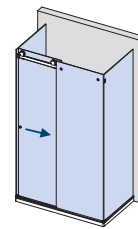

SET 4

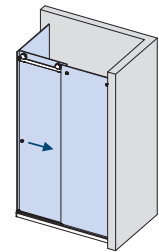

SET 5

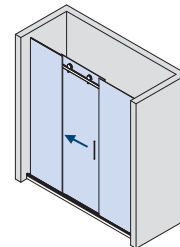

SCORREVOLI

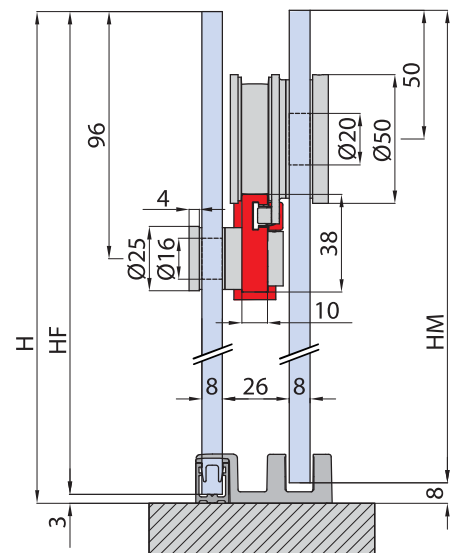

BX-6050 SET 1

MY METALGLAS

L = 1000 x 1000mm

DOCCIA IN ANGOLO / CORNER SHOWER / ECKDUSCHE

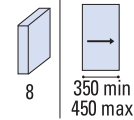

Fin. / Fin. / Oberf.

CR	IX	NO
Cromo lucido	Effetto inox satinato	Nero opaco
Polished chrome	Inox effect	Matt black
Chrom glänzend	Inox effekt	Schwarz matt

COMPONENTI / COMPONENTS / EINZELTEILE

- BX-6050-C90 (2x)
- BX-6050-C70 (4x)
- BX-6050-C30 (2x)
- BX-6050-C10 (4x)
- BX-6050-C20 (1x)
- OPTIONAL

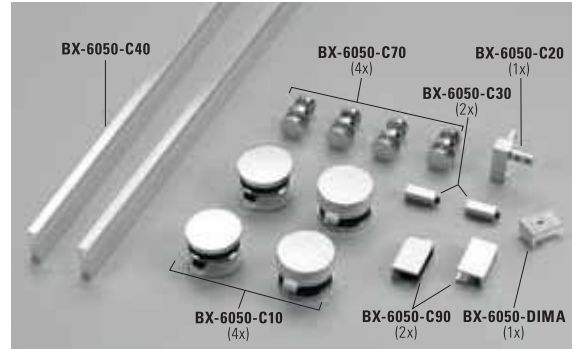
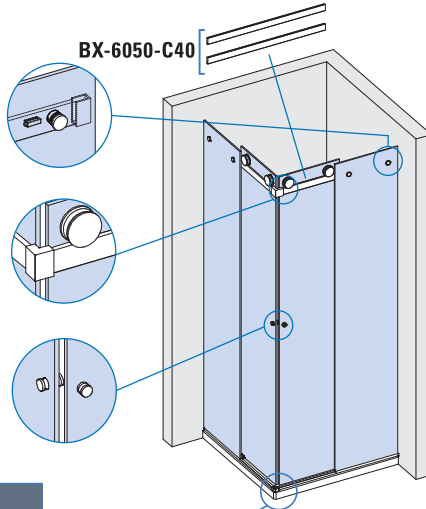

CARATTERISTICHE COMPONENTI / FEATURES COMPONENTS / EIGENSCHAFTEN EINZELTEILE ▶ 80

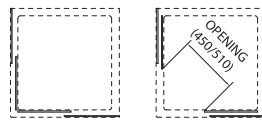
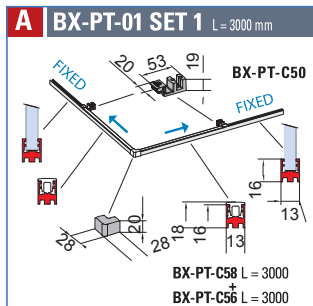

PROFILI A TERRA / FLOOR PROFILES / BODENPROFILE ▶ 106

xme627a

BX-6050 SET 2

MY METALGLAS

L = 1500mm / L = 3000mm

DOCCIA IN NICCHIA / NICHE SHOWER / NISCHENDUSCHE

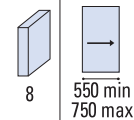

Fin. / Fin. / Oberf.

CR	IX	NO
Cromo lucido	Effetto inox satinato	Nero opaco
Polished chrome	Inox effect	Matt black
Chrom glänzend	Inox effekt	Schwarz matt

COMPONENTI / COMPONENTS / EINZELTEILE

- BX-6050-C10 (2x)
- BX-6050-C90 (2x)
- BX-6050-C70 (2x)
- BX-6050-C30 (1x)
- OPTIONAL

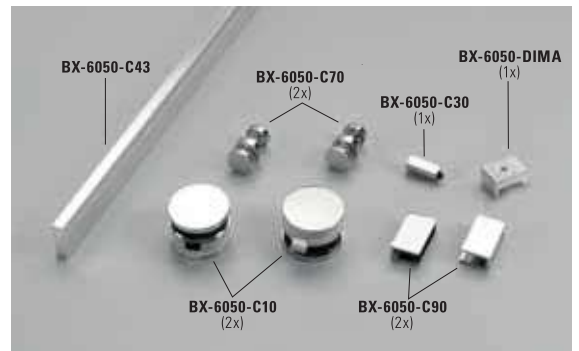
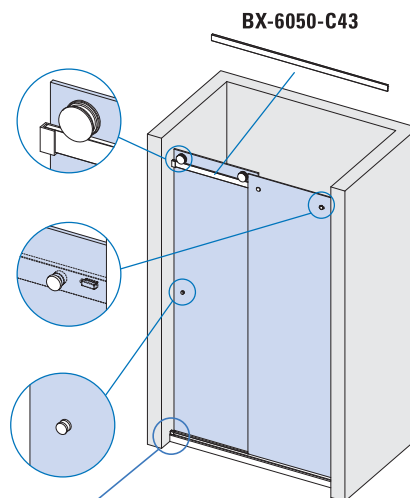

CARATTERISTICHE COMPONENTI / FEATURES COMPONENTS / EIGENSCHAFTEN EINZELTEILE ▶ 80

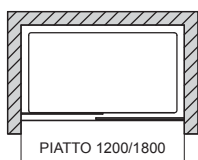
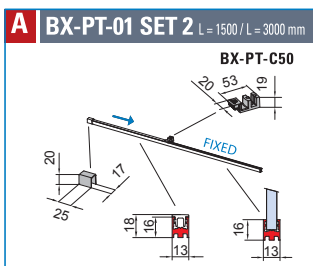

PROFILI A TERRA / FLOOR PROFILES / BODENPROFILE ▶ 106

xme627a

SCORREVOLI

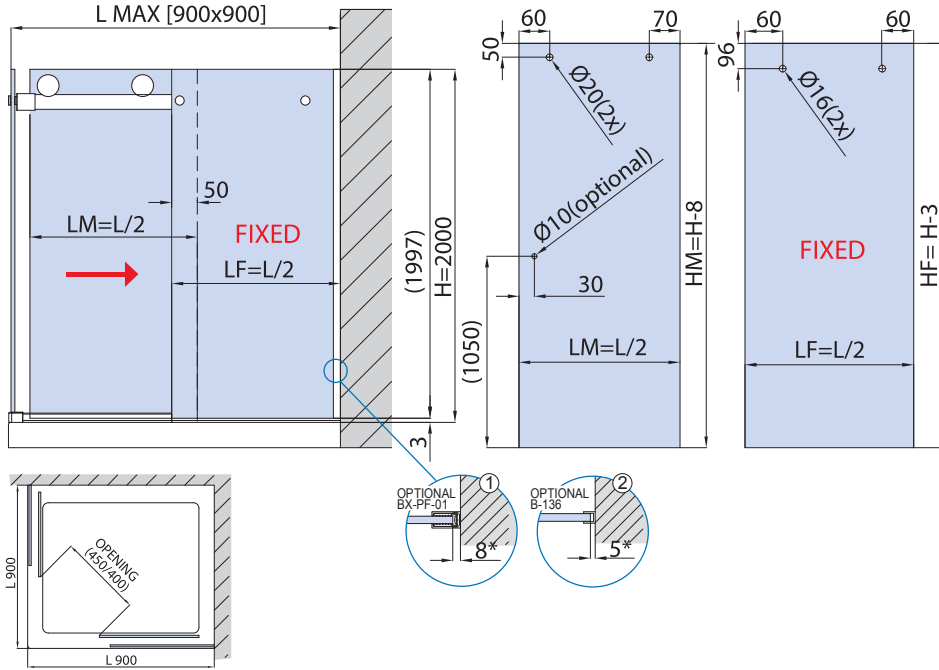
LAVORAZIONE VETRO / GLASS PREPARATION / GLASBEARBEITUNG

CALCOLO VETRO / CALCULATION GLASS / GLASBERECHNUNG

PIATTO - SHOWER TRAY - DUSCHTASSE (L) = (900x900) mm

Vetro Mobile Larghezza (LM) = L / 2

Vetro Fisso Larghezza (LF) = [(L / 2)] - * ① / * ② (aria variabile / clearance / Spaltmaß)

Vetro Mobile Altezza (HM) = H - 8 = 1992 mm

PROFILI A TERRA / FLOOR PROFILES / BODENPROFILE ▶ 106
BX-PT-01 STANDARD HF = H - 3 = 1997 mm

xme627b

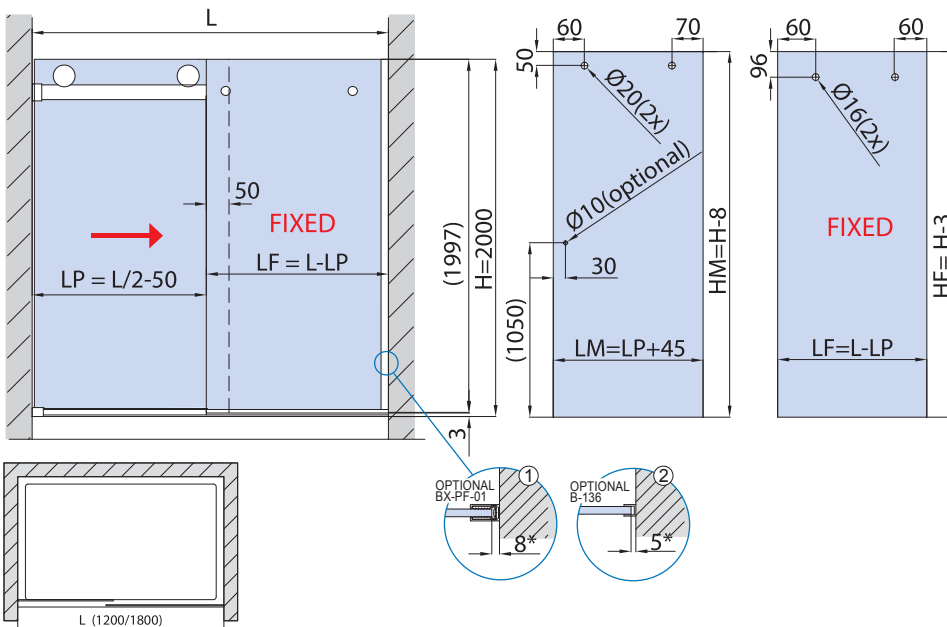
CALCOLO VETRO / CALCULATION GLASS / GLASBERECHNUNG

L = PIATTO - SHOWER TRAY - DUSCHTASSE

Passaggio (LP) = L / 2 - 50

Vetro Mobile Larghezza (LM) = LP + 45

Vetro Fisso Larghezza (LF) = L - LP - * ① / * ② (aria variabile / clearance / Spaltmaß)

Vetro Mobile Altezza (HM) = H - 8 = 1992 mm

PROFILI A TERRA / FLOOR PROFILES / BODENPROFILE ▶ 106
BX-PT-01 STANDARD HF = H - 3 = 1997 mm

xme627b

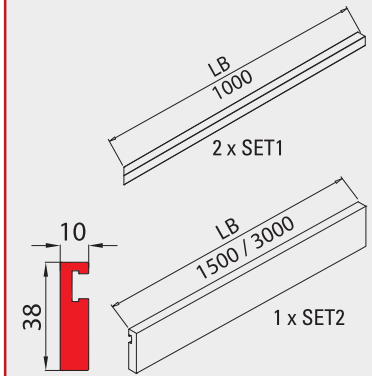
SET 1 / SET 2
DA TAGLIARE / ADJUST THE LENGTH / BELIEBIG KÜRZBAR ✂

- Regolazione ± 3 mm.
- Adjustment ± 3 mm.
- Verstellung ± 3 mm.

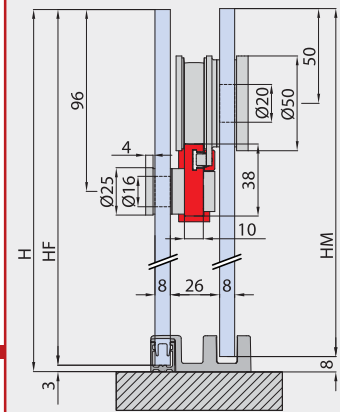
 HM = H - 8
 HF = H - 3
 solo per / only for / nur für **BX-PT-01**
OPTIONAL



L	LP	LM	LF	HM	HF	H
Piatto Shower tray Duschtasse	Passaggio luce Clear opening width Lichte Durchgangsbreite	Larghezza vetro mobile Sliding glass width Schiebeflügel Breite	Larghezza vetro fisso Side fixed glass width Seitenteil Breite	Altezza vetro mobile Sliding glass height Schiebeflügel Höhe	Altezza vetro fisso Side fixed glass height Seitenteil Höhe	Altezza doccia Shower height Duschkabine Höhe

BX-6050 SET 3

L = 1500mm / L = 3000mm

DOCCIA A U / U SHOWER / U DUSCHE

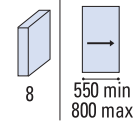
MY METALGLAS



Fin. / Fin. / Oberf.

CR	IX	NO
Cromo lucido	Effetto inox satinato	Nero opaco
Polished chrome	Inox effect	Matt black
Chrom glänzend	Inox effekt	Schwarz matt

COMPONENTI / COMPONENTS / EINZELTEILE

BX-6050-C10 (2x)

BX-6050-C90 (2x)
BX-6050-C81 (2x)

BX-6050-C70 (2x)

BX-6050-C30 (1x)

OPTIONAL

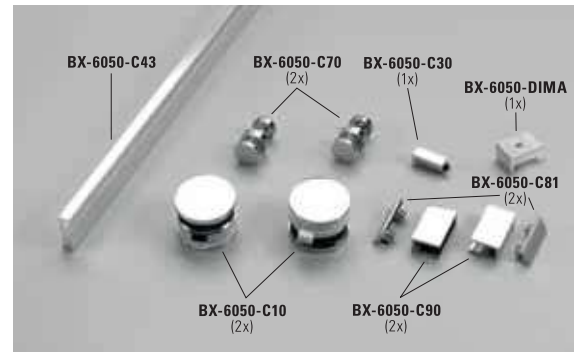
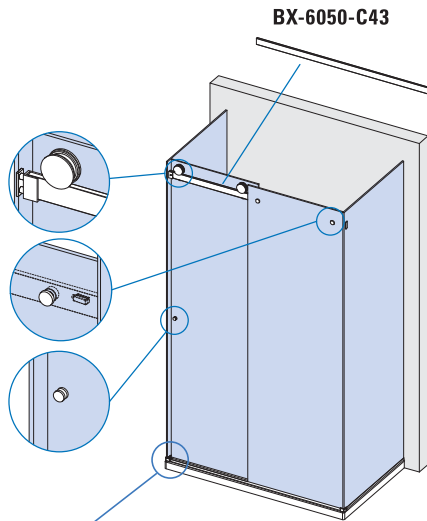

CARATTERISTICHE COMPONENTI /
FEATURES COMPONENTS /
EIGENSCHAFTEN EINZELTEILE ▶ 80

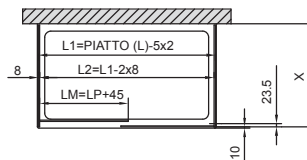
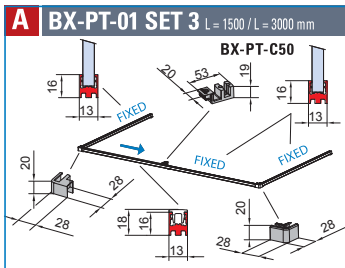

PROFILI A TERRA / FLOOR PROFILES / BODENPROFILE ▶ 106

xme627a

BX-6050 SET 4

L = 1500mm / L = 3000mm

DOCCIA CON SPALLA IN VETRO / CORNER SHOWER WITH 2 FIXED PANELS
ECKDUSCHE MIT 2 FESTSTEHENDEN GLASTAFELN

MY METALGLAS

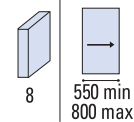

Fin. / Fin. / Oberf.

CR	IX	NO
Cromo lucido	Effetto inox satinato	Nero opaco
Polished chrome	Inox effect	Matt black
Chrom glänzend	Inox effekt	Schwarz matt

COMPONENTI / COMPONENTS / EINZELTEILE

BX-6050-C10 (2x)

BX-6050-C90 (2x)
BX-6050-C81 (1x)

BX-6050-C70 (2x)

BX-6050-C30 (1x)

OPTIONAL

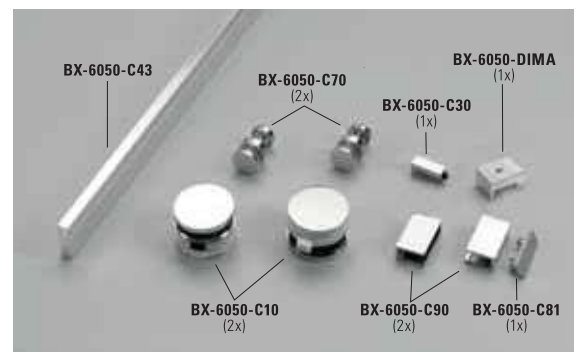
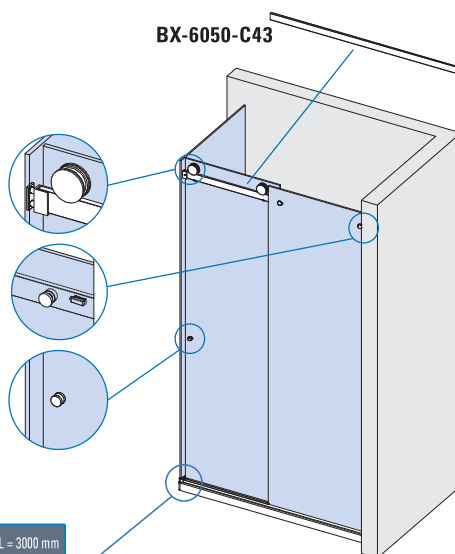

CARATTERISTICHE COMPONENTI /
FEATURES COMPONENTS /
EIGENSCHAFTEN EINZELTEILE ▶ 80

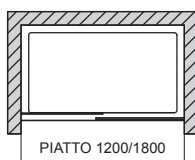
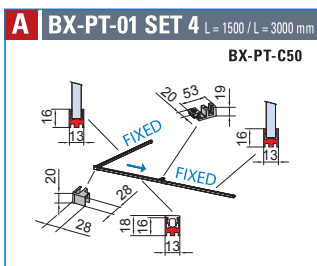

PROFILI A TERRA / FLOOR PROFILES / BODENPROFILE ▶ 106

xme627a

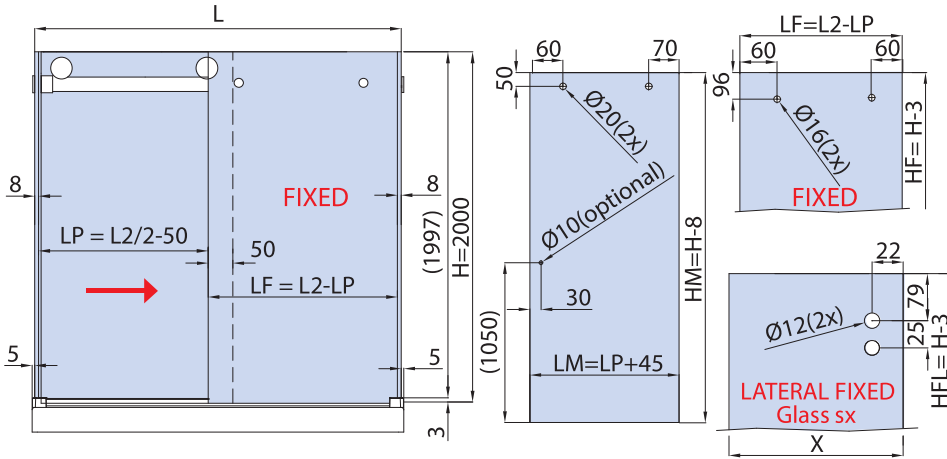
LAVORAZIONE VETRO / GLASS PREPARATION / GLASBEARBEITUNG

CALCOLO VETRO / CALCULATION GLASS / GLASBERECHNUNG

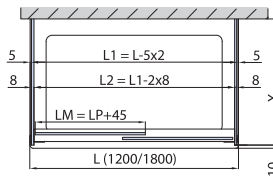
L = PIATTO - SHOWER TRAY - DUSCHTASSE
 L1 = PIATTO (L) - 5x2
 L2 = L1 - 2x8
 Passaggio (LP) = L2 / 2 - 50
 Vetro Mobile Larghezza (LM) = LP + 45
 Vetro Fisso Larghezza (LF) = L2 - LP
 X = CALCOLARE / CALCULATE / BERECHNEN
 Vetro Mobile Altezza (HM) = H - 8 = 1992 mm

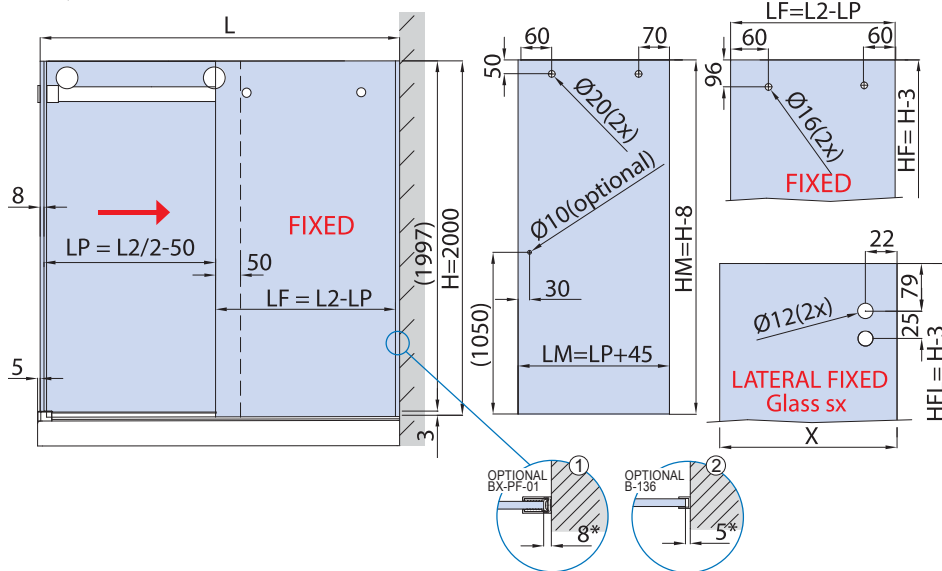

PROFILI A TERRA / FLOOR PROFILES / BODENPROFILE ▶ 106

BX-PT-01 STANDARD HF = H - 8 = 1992 mm HFL = H - 3

xme627c

CALCOLO VETRO / CALCULATION GLASS / GLASBERECHNUNG

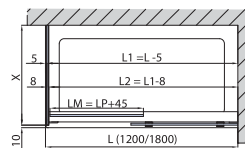
L = PIATTO - SHOWER TRAY - DUSCHTASSE
 L1 = PIATTO (L) - 5
 L2 = L1 - 8
 Passaggio (LP) = L2 / 2 - 50
 Vetro Mobile Larghezza (LM) = LP + 45
 Vetro Fisso Larghezza (LF) = L2 - LP - * (1) / * (2) (aria variabile / clearance / Spaltmaß)
 X = CALCOLARE / CALCULATE / BERECHNEN
 Vetro Mobile Altezza (HM) = H - 8 = 1992mm



PROFILI A TERRA / FLOOR PROFILES / BODENPROFILE ▶ 106

BX-PT-01 STANDARD HF = H - 3 = 1997 mm

xme627c

SET 3 / SET 4

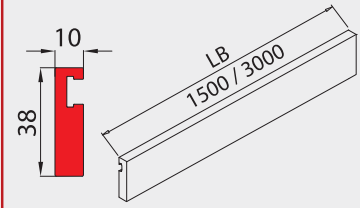
DA TAGLIARE / ADJUST THE LENGTH / BELIEBIG KÜRZBAR ✂



- Regolazione ± 3 mm.
- Adjustment ± 3 mm.
- Verstellung ± 3 mm.

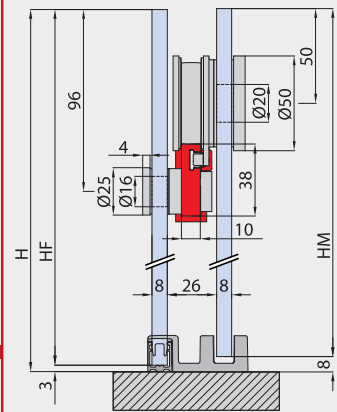

HM = H - 8
 HF = H - 3
 solo per / only for / nur für
BX-PT-01

OPTIONAL

L	LP	LM	LF	HM	HF	H
Piatto Shower tray Duschtaße	Passaggio luce Clear opening width Lichte Durchgangsbreite	Larghezza vetro mobile Sliding glass width Schiebeflügel Breite	Larghezza vetro fisso Side fixed glass width Seitenteil Breite	Altezza vetro mobile Sliding glass height Schiebeflügel Höhe	Altezza vetro fisso Side fixed glass height Seitenteil Höhe	Altezza doccia Shower height Duschkabine Höhe

BX-6050

COMPONENTI / COMPONENTS / EINZELTEILE

SCORREVOLI



BX-6050-C43/ BX-6050-C40

- Binario
- Track profile
- Laufschiene

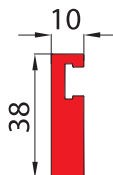

- Forature per fissaggio vetro fisso (ad opera dell'installatore con dima di foratura)
- Drilling for fixed glass by the installer (template included in Set)
- Bohrungen für Festverglasung bauseitig (Schablone im device Set enthalten)

Cod.	Fin. / Fin. / Oberf.
BX-6050-C43-1500 mm	CR / IX / NO
BX-6050-C43-3000 mm	CR / IX / NO
BX-6050-C40-1000 x 1000 mm (2 pcs)	CR / IX / NO

xme556i



BX-6050-C10

- Ruota con antigancio
- Roller with antijump
- Laufrolle und Aushebeschutz

CR - NS - NO

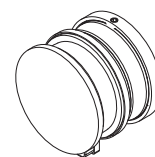
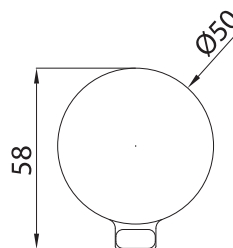
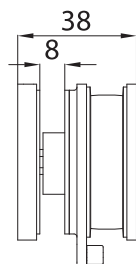

xme627d



BX-6050-C70

- Punto di fissaggio vetro fisso al binario
- Fixing point for fixed glass and track profile
- Punkthalter für Fixierung des Festteils auf Laufschiene

CR - NS - NO

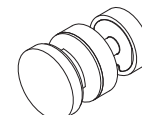
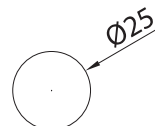
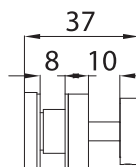

xme627d



BX-6050-C90 DX

- Attacco a parete destro per binario
- Right wall connector for track profile
- Wandhalter rechts für Laufschiene

CR - NS - NO

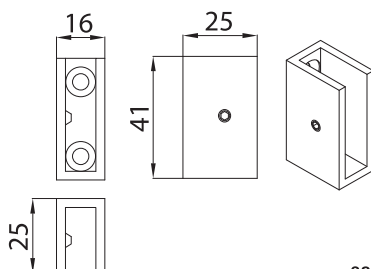

xme627d



BX-6050-C90 SX

- Attacco a parete sinistro per binario
- Left wall connector for track profile
- Wandhalter links für Laufschiene

CR - NS - NO

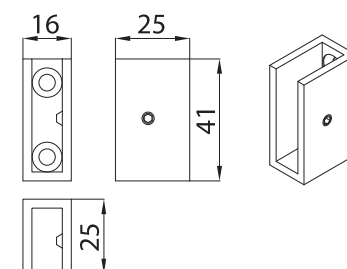

xme627d

BX-6050-C30

- Stopper
- CR - NS - NO

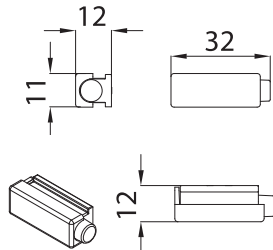

xme627d

BX-6050-C20

- Connettore ad angolo per binari set 1
- Corner connector for track profiles set 1
- Winkelverbinder Laufschiene set 1
- CR - NS - NO

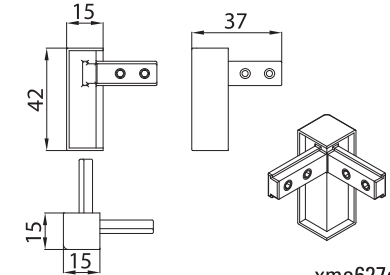

xme627d

BX-6050-C81

- Piastrina attacco a vetro per BX-6050-C90
- Plate glass connector for BX-6050-C90
- Platte Glashalter für BX-6050-C90
- CR - NS - NO

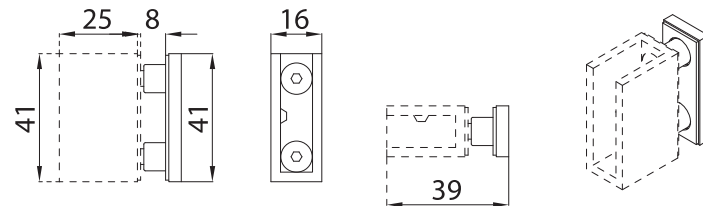

xme627d

BX-PT-C50

- Guida vetro scorrevole per applicazione con profilo a terra.
- Floor guide sliding panel for installation with floor profile.
- Schiebetür Bodenführung für Montage mit Bodenprofile.
- CR - NS - NO

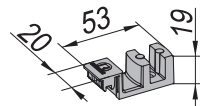
BX-6050-DIMA

- Dima per foratura per morsetto vetro fisso
- Template for drilling the track profile with the clamp
- Schablone für das Bohren der Laufschiene mit der Klemme

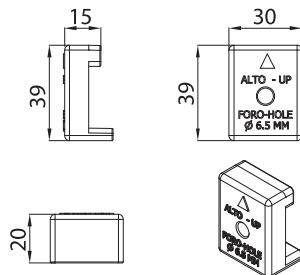

xme627d

BX-PT-C58

- Profilo per fissaggio a terra o laterale
- Profile for floor and side installation
- Profil Boden- Wandmontage

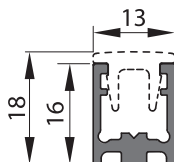

Cod.	Fin./Fin./Fin.
BX-PT-C58-1500 mm	CR / IX / NO
BX-PT-C58-3000 mm	CR / IX / NO

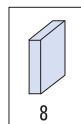
BX-PT-C56

- Coperchio per profilo a terra per tratto entrata doccia
- Cover profile for floor profile, shower entry.
- Profilabdeckung Bodenprofil Duscheinstieg

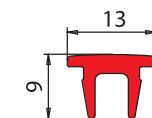

Cod.	Fin./Fin./Fin.
BX-PT-C56-1500 mm	CR / IX / NO
BX-PT-C56-3000 mm	CR / IX / NO