

INVISIBLE (OPTIONAL SOFT-CLOSE) BINARI INVISIBILI



V-7603



8-10	8,76/10,76/12 12,76/13,52 con V-5607	500 min 1000 max



INVISIBILE

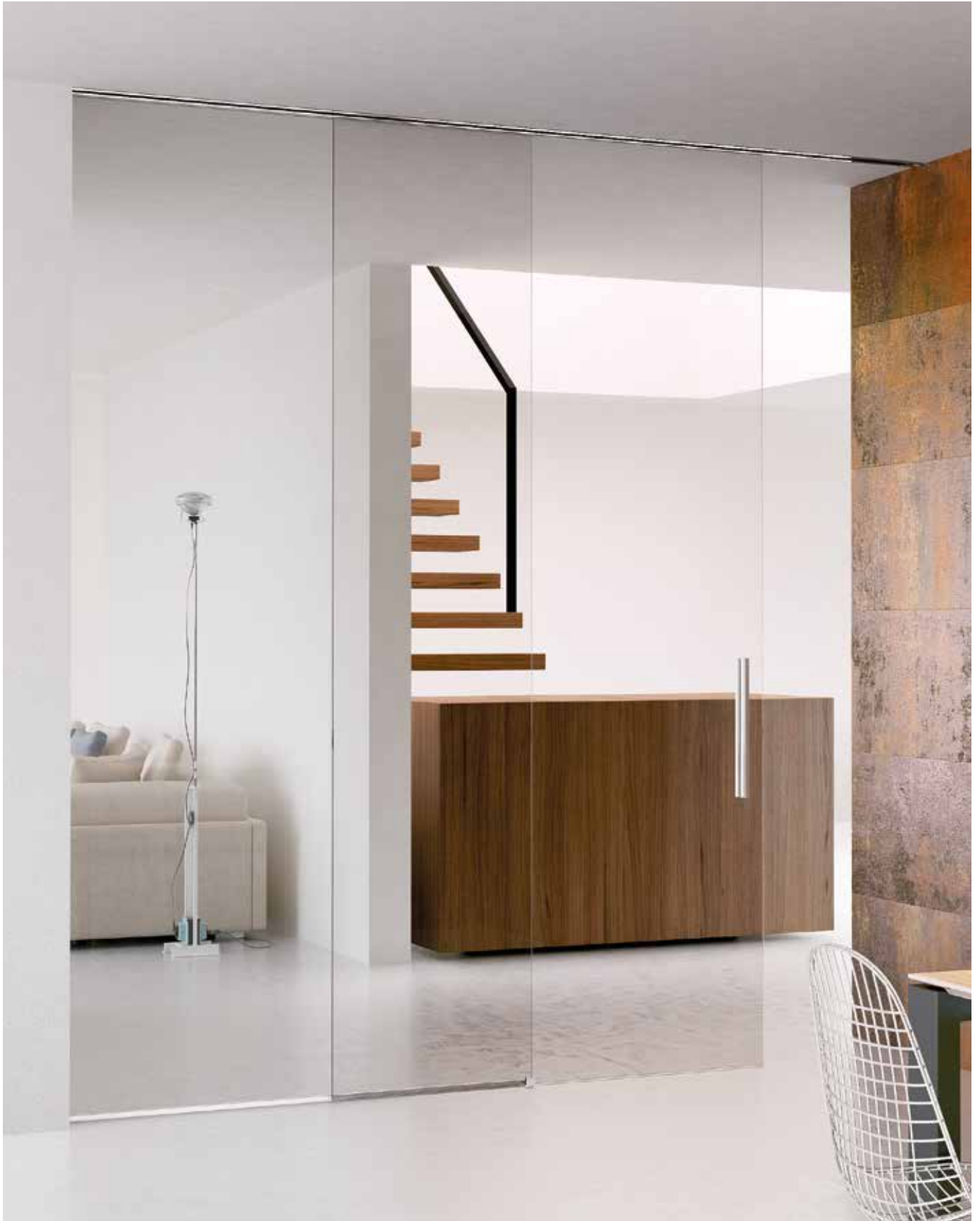

COMPONENTI ▶ 130

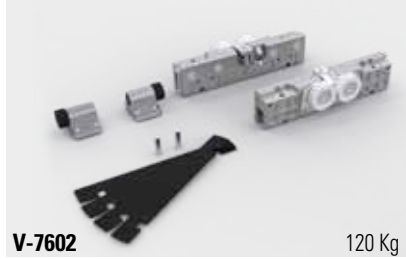
V-7603

V-7602

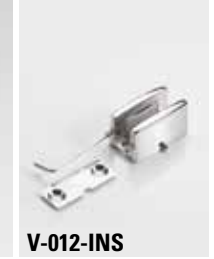
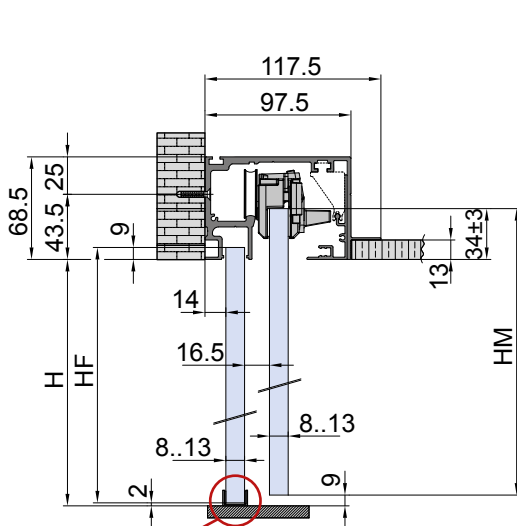
• Regolazione dal basso

V-5606-70 70 Kg | **V-5606-80** 80 Kg
V-5606-100 100 Kg | **V-5606-120** 120 Kg

V-012-INS

NON INCLUSO

$$HM = H + 25$$

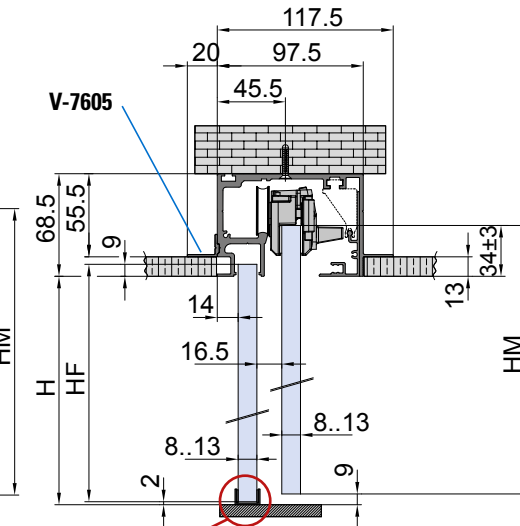
$$HF = H + 7$$



NON INCLUSO

$$HM = H + 25$$

$$HF = H + 7$$

OPTIONAL	
VP-019-MT	VP-018-MT
1000 mm - 2000 mm - 3000 mm	
• Guarnizioni per sede vetro fisso	

INVISIBILE

V-7603 SET 1

• Set per 1 anta scorrevole e vetro fisso, fissaggio a parete/soffitto

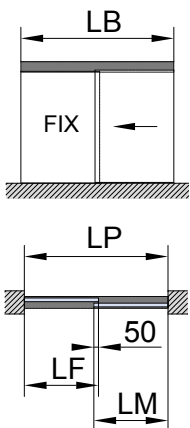

$$LB = LP$$

$$LM/LF = (LP+50)/2$$

V-7603 SET 2

• Set per 2 ante scorrevoli e vetri fissi, fissaggio a parete/soffitto

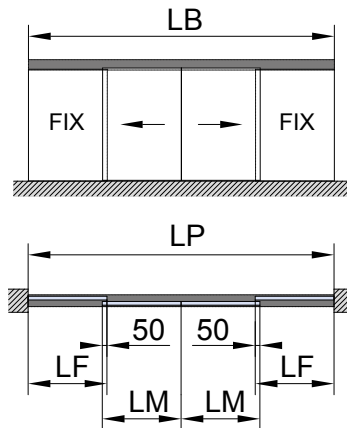

$$LB = LP$$

$$LM/LF = (LP+100)/4$$

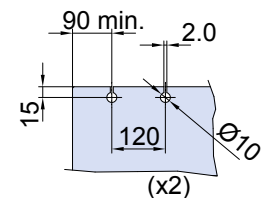
 • Fori vetro sicurezza **optional**

xme576g

Componenti ▶ 130	Fin.	V-7603 SET 1	V-7603 SET 2
V-7603 L=2000 L=3000 L=4000 L=6000	AN	1	1
V-7605 L=2000 L=3000 L=4000 L=6000 (OPTIONAL)	GR	(1)	(1)
V-7602	-	1	2
V-5606-70 Kg / V-5606-80 Kg / V-5606-100 Kg / V-5606-120 Kg (OPTIONAL)	-	(1)	(2)
V-012-INS	AN	1	2