

B-7040 SHARK





- Unire minimo impatto estetico ed efficienza meccanica: questo l'obiettivo e il risultato ottenuto con la Pensiline SHARK, che garantisce una resistenza eccezionale ai carichi, pur in assenza di supporti o tiranti. Un profilo in alluminio studiato appositamente per permettere una salda presa del vetro e una tenuta solidissima una volta fissato al muro, sono il segreto di questa soluzione assolutamente innovativa. Il risultato estetico è da vedere: estrema pulizia e assoluta linearità del disegno, fanno in modo che il vetro sembri sospeso al muro per virtù propria. Questa è la magia della ricerca tecnologica che sta alla base della Pensiline SHARK.
- The aim was to bring together aesthetic impact and mechanical efficiency and this was achieved with the SHARK Canopy, which guarantees an exceptional level of resistance to loads even though there are no supports or stay rods. The secret of this highly innovative solution is an aluminium frame that has been especially designed to have a strong grip on the glass and to give a very firm hold once it is fixed to the wall. The aesthetic result is unmissable; extremely clean and a design that is absolutely linear making the glass seem attached to the wall on its own. This is the magic of the technical research that is the foundation of the SHARK Canopy.
- Geringe Beeinträchtigung der Optik kombiniert bei wirksamer Mechanik: das ist das Ziel und Ergebnis des Vordaches SHARK, das trotz des Fehlens von Halterungen oder Zugstangen maximale Tragfähigkeit garantiert. Ein eigens entwickeltes Alu-Profil, das eine sichere Glasaufnahme und einen perfekten Halt nach der Wandmontage garantiert, ist das Geheimnis dieser absolut innovativen Lösung. Die Optik ist sehenswert: die klare Linien führen dazu, dass das Glas von allein an der Wand befestigt erscheint. Dies ist die Faszination der technologischen Forschungsarbeit, die hinter dem Vordach SHARK steht.



B-7040 SHARK

€ H.000 → € H.000

PENSILINE IN VETRO / GLASS CANOPY / VORDACH SYSTEM



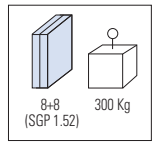
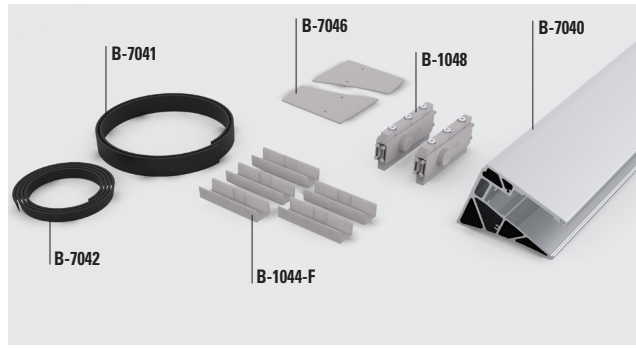
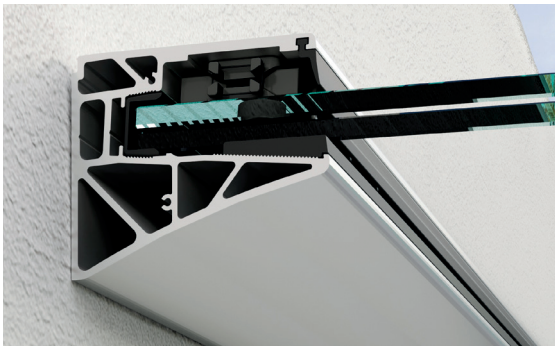

B-7040

B-SET-7040

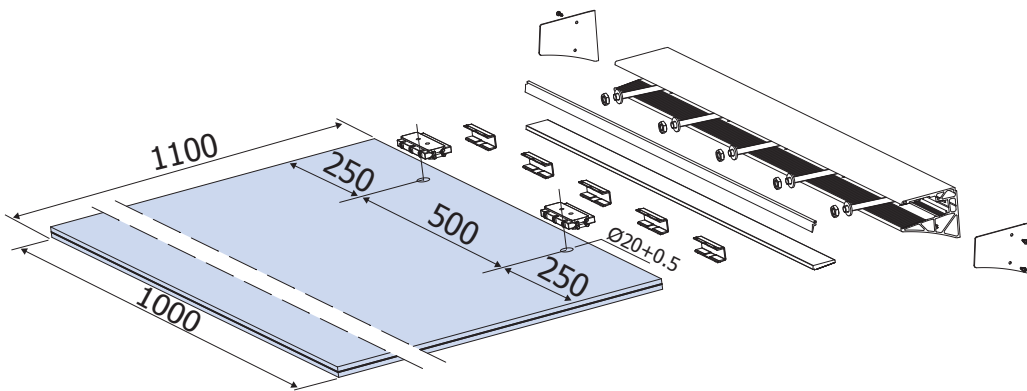

- Lavorazione vetro.
- Glass preparation.
- Glasbearbeitung.

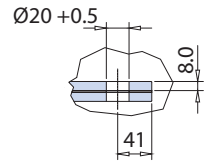

- Lavorazione vetro alternativa. Solo la lastra superiore è forata.
- Alternative glass preparation. Only the upper glass panel is drilled.
- Alternative Glasbearbeitung. Nur die obere Scheibe wird gebohrt.

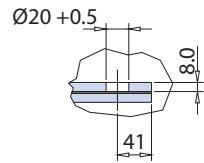

B-7040 set 1

L = 1000 mm
con/with/mit
2 Jolly Pack

- N. 2 pcs
- N. 5 pcs

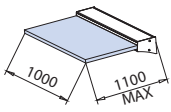

B-7040 set 1,5

L = 1500 mm
con/with/mit
3 Jolly Pack

- N. 3 pcs
- N. 8 pcs

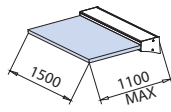

B-7040 set 2

L = 2000 mm
con/with/mit
4 Jolly Pack

- N. 4 pcs
- N. 10 pcs

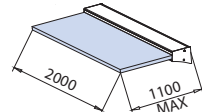

B-7040 set 3

L = 3000 mm
con/with/mit
6 Jolly Pack

- N. 6 pcs
- N. 16 pcs

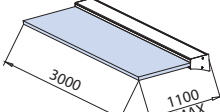

B-7040 set 4

L = 4000 mm
con/with/mit
8 Jolly Pack

- N. 8 pcs
- N. 20 pcs

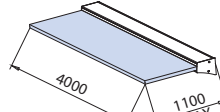

B-7040 set 6

L = 6000 mm
con/with/mit
12 Jolly Pack

- N. 12 pcs
- N. 30 pcs

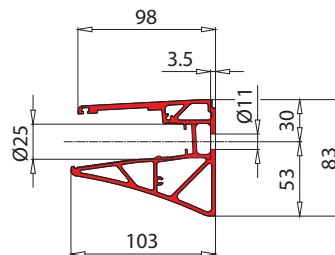
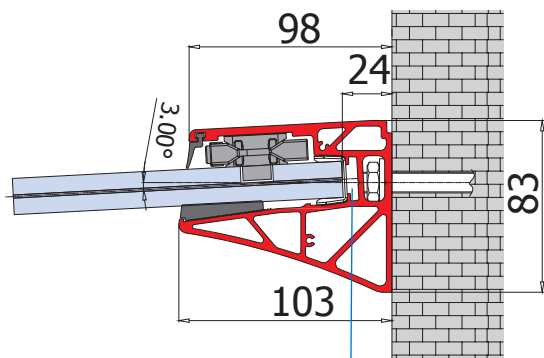
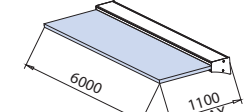

Quota variabile / Variable size / Variables Maß

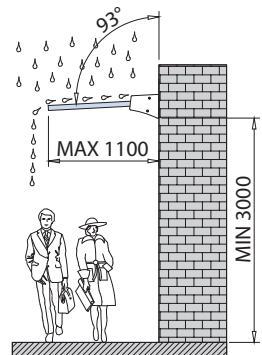
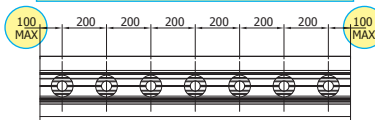

- Sede per LED 18x5 max, per illuminazione vetro
- Channel for LED, for glass lighting
- Sitz für LED, für Beleuchtung des Glas