

B-5500 MAXIMA STADIUM / B-5600 MAXIMA STADIUM TRIPLO VETRO

€▶ H.16 €▶ H.17

- Progettato per stadi e luoghi pubblici per assorbire una grande spinta che, dai primi test aziendali, supera i 500 Kg, con lievi deformazioni del profilo.
- The product has been designed for the stadium and public area. This balustrade can grant a big side force which according to internal test can go over 500 kg force without profile deformation.
- Das Produkt wurde für Stadien und öffentliche Räume entwickelt. Die Balustrade kann große Kräfte aufnehmen. Internationale Tests beweisen, dass Kräfte über 500 kg aufgenommen werden können, ohne das Profil zu deformieren.

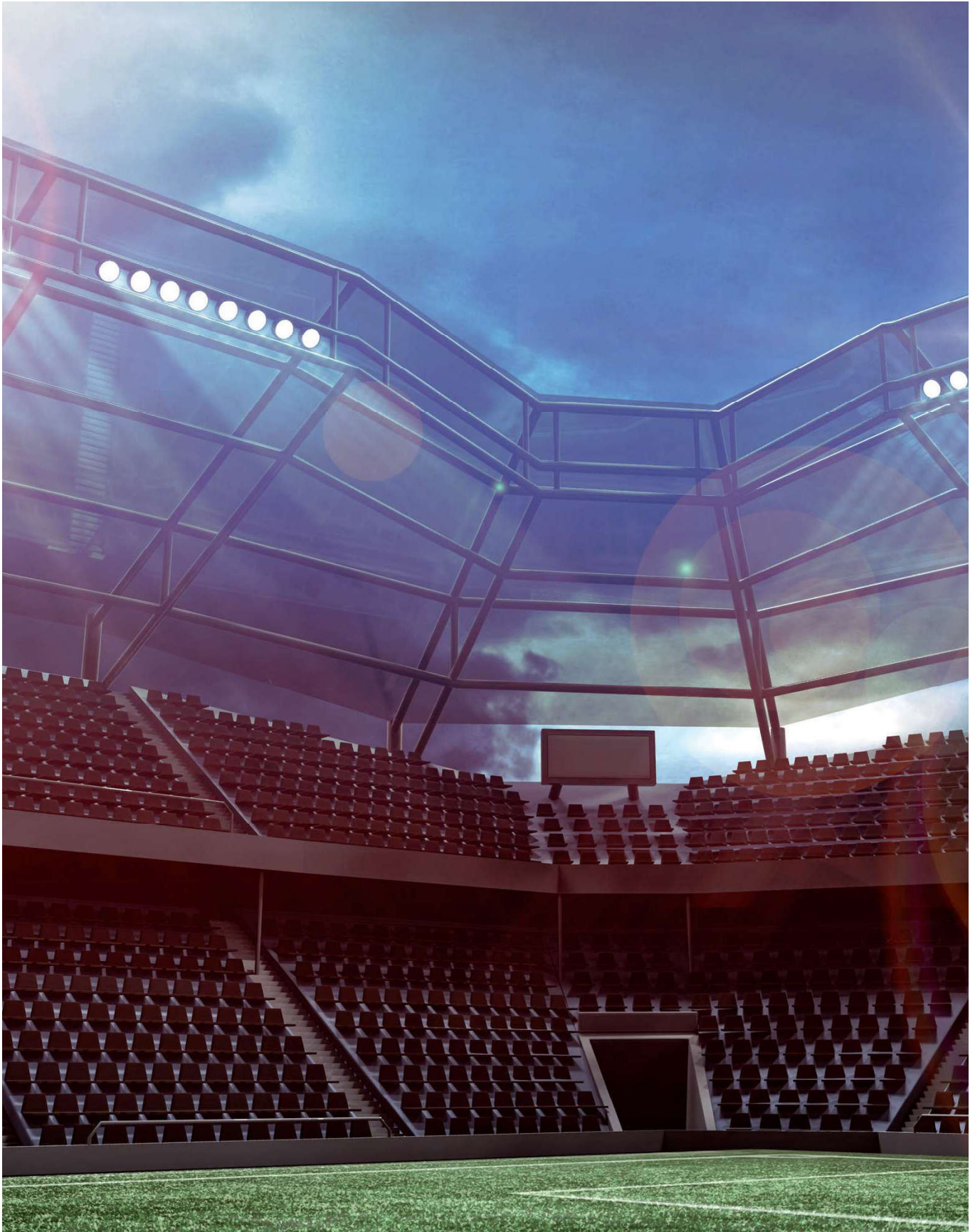

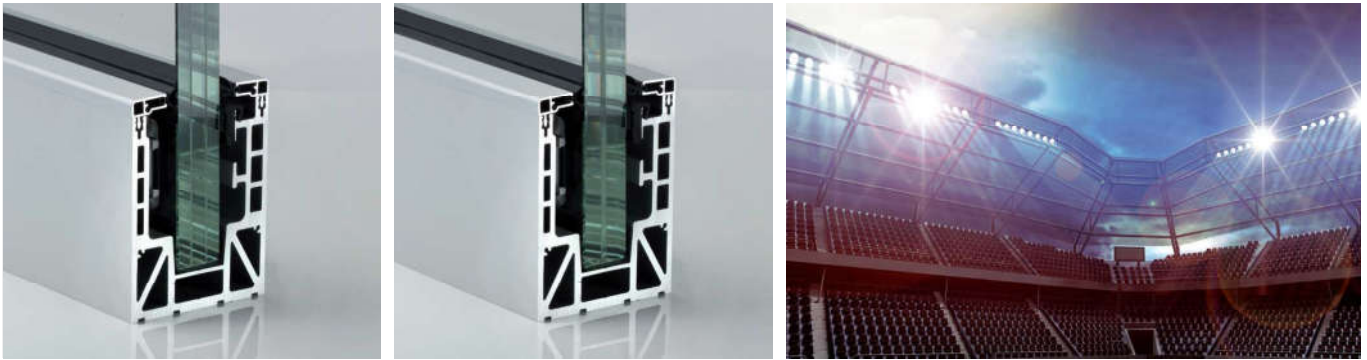
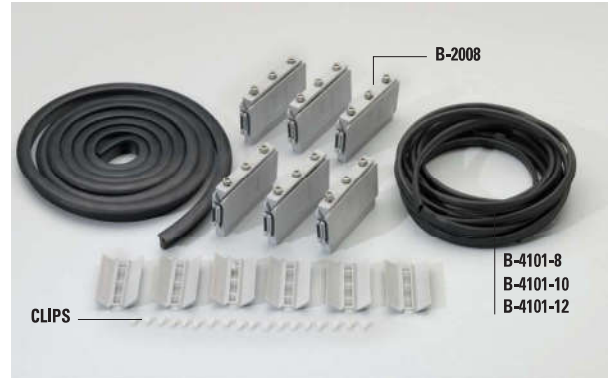
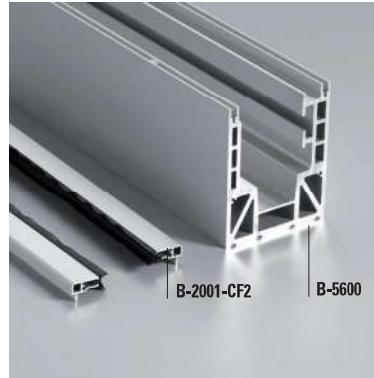

COMPONENTI / COMPONENTS / EINZELTEILE

B-5500+B-2001-CF2

- Profilo balastra + 2 Vele
- Railing profile + 2 Cover profiles
- Profil für Geländer mit 2 Abdeckungen

B-5600+B-2001-CF2

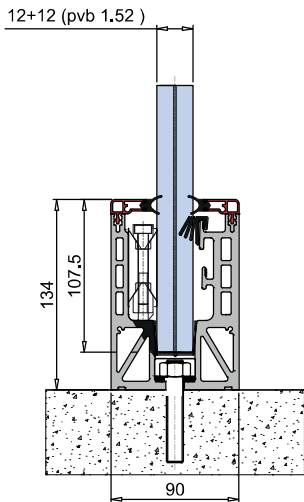
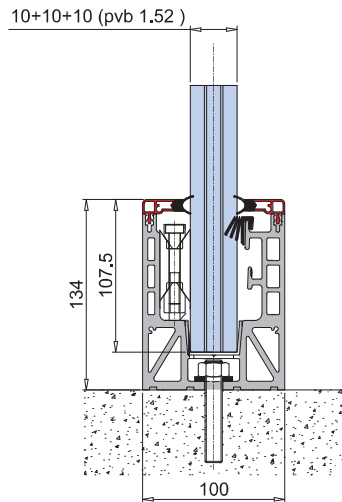
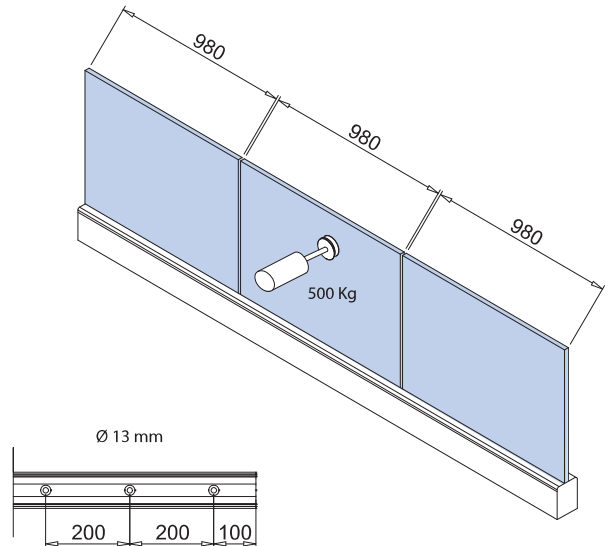
- Profilo balastra + 2 Vele
- Railing profile + 2 Cover profiles
- Profil für Geländer mit 2 Abdeckungen

- Set morsetti e guarnizioni
- Set clamps and gaskets
- Set Klemmen und Dichtungen

B-5500

B-5600

Set completo/mt L = 3000 mm Complete set/mt L = 3000 mm Komplett-Set L = 3000 mm	Vetro Glass Glas	Testato spinta Test side force Gefestete Seitenkraft	Deflection
--	------------------------	--	------------

B-5500-BS-12

12+12+1,52 SGP

300 kg

23,20 mm

SET COMPOSTO DA SET CONSISTING OF SET BESTEHEND AUS	FIN. FIN. OB.	B-5500 SET 4,5 KN 12	B-5600 SET 10
B-5500 + B-2001-CF2	AN	1 pz/pcs L = 3000 mm	-
B-SET-MAX-AbP 12	-	1	-
B-5600 + B-2001-CF2	AN	-	1 pz/pcs L = 3000 mm
B-SET-MAX-TRIP	-	-	1